

E-BUSINESS APPLICATIONS R12 (RUP 3) RECEIVABLES BATCH PROCESSING: Using Oracle10g on an IBM System p5 595

As a global leader in e-business applications, Oracle is committed to delivering high performance solutions that meet our customers' expectations. Business software must deliver rich functionality with robust performance. This performance must be maintained at volumes that are representative of customer environments. Oracle benchmarks demonstrate our software's performance characteristics for a range of processing volumes in a specific configuration. Customers and prospects can use this information to determine the software, hardware, and network configurations necessary to support their processing volumes. The primary objective of our benchmarking effort is to provide as many data points as possible to support this important decision.

'TELECOM SCENARIO' PROFILE

In May and June 2008, Oracle conducted a benchmark in the Oracle/IBM Joint Solution Center in Montpellier (Part of the largest European support center for IBM systems) to measure the online and batch performance of Receivables flows (processes) in an environment running Oracle E-Business Suite R12 (RUP 3) with Oracle10g™ (10.2.0.3) RAC for the IBM AIX® operating system on twin 54-CPU partitions of twin IBM® System p5™ 595 database servers running AIX 5L™ V5.3 TL06 (64-bit) OS. Two (or four) 10-CPU partitions of the IBM System p5-595 servers were used as Application/Web servers.

An IBM System Storage® DS8300 Turbo, equipped with 384 disk arrays totaling 80 TB were used for data storage. Actual database was ~12 TB.

The testing measured the Receivables batch business process hourly throughputs for a small database model. Testing was conducted in a controlled environment for OLTP and Batch flows. **The goal of this Benchmark was to obtain sizing and performance results for a telecommunications scenario with 42 Million customers and 4 months of history data.**

CONCLUSION

The batch flows were completed in 9.6–14.3 hours with the database servers averaging about 90–93% CPU utilization of 50 cores.

SUMMARY OF BATCH RESULTS

Process	42 Million Customers 4 Months History	Threads	Time Hr:Mn	Throughput per Hour
Autoinvoice				
Master 1	13,657,852	128	3:44:10	3,655,633
Master 2	13,472,276	128	3:44:43	3,597,137
Master 4	325,272	5	0:28:03	695,769
CreateAccounting for Invoices				
Master 1		10	0:56:57	
Master 2		10	0:54:00	
Master 3		10	2:48:21	
Master 4		10	1:16:16	
Master 5		10	2:01:47	
Master 6		10	0:10:15	
Node 1	<i>Invoice Flow</i>	Total:	9:40:21	

Lockbox_Post Batch	88,200	20	2:22:31	38,242
Auto_Recpt	2,515,800	140	4:32:50	553,261
Remittance	2,515,800	120	4:17:45	585,637
Clearace	2,515,800	120	4:25:34	568,400
CA(Rec)	2,604,000	64	0:53:42	2,909,497
Node 2	<i>Payment Flow</i>	Total:	14:20:53	

Note that the batch workloads and the hourly throughput numbers mentioned above are linear extrapolations. Many factors can influence performance and your results may differ.

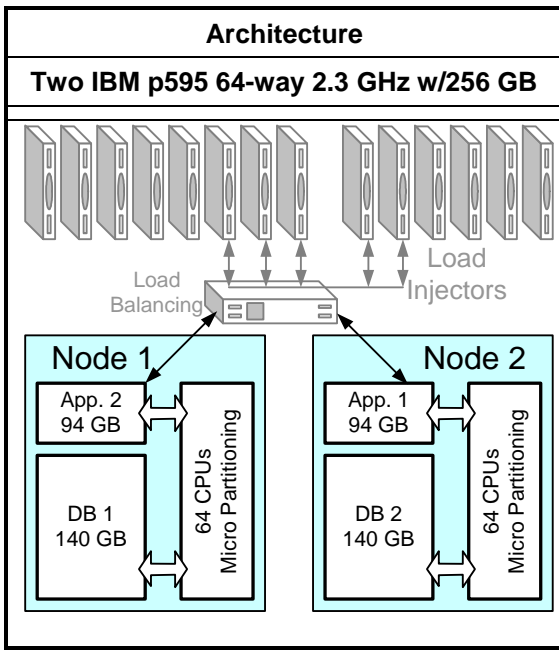

Throughputs Achieved

AR Autoreceipts	550 K receipts per hour
AR Autoremittance	590 K receipts per hour
AR Autoclearance	560 K receipts per hour
Create Accounting Receipts	3.6 million receipts/events per hour

Note:

- Average number of lines per invoice is 11.
- Create Accounting timings include Transfer to GL and GL Posting.

Figure 1: Summary of Test Configuration

Transaction	Volume		Threads	H:MM:SS	Seconds	Hourly	Hourly/Thread
AutoInvoice_Master_1	13,657,852	Lines	128	3:44:10	13,450	3,655,633	28,560
AutoInvoice_Master_2	13,472,276	Lines	128	3:44:43	13,483	3,597,137	28,103
AutoInvoice_Master_3	325,272	Lines	5	0:28:03	1,683	695,769	139,154
CreateAccounting_Invoice_Master_1			10	0:56:57	3,417		
CreateAccounting_Invoice_Master_2			10	0:54:00	3,240		
CreateAccounting_Invoice_Master_3			10	2:48:21	10,100		
CreateAccounting_Invoice_Master_4			10	1:16:16	4,576		
CreateAccounting_Invoice_Master_5			10	2:01:47	7,307		
CreateAccounting_Invoice_Master_6			10	0:10:15	623		
Node 1	Invoice	Flow		9:40:21			
Lockbox_PostBatch	88,200	Receipts	20	2:22:31	8,303	38,242	1,912
Auto_Recpt	2,515,800	Receipts	140	4:32:50	16,370	553,261	3,952
Remittance	2,515,800	Receipts	120	4:17:45	15,465	585,637	4,880
Clearance	2,515,800	Receipts	120	4:25:34	15,934	568,400	4,737
CA(Rec)	2,604,000	Events	64	0:53:42	3,222	2,909,497	45,461
Node 2	Payment	Flow		14:20:53			

Table 1: Summary of Batch Execution Times and Extrapolated Throughput.

BENCHMARK METHODOLOGY

E-Business Suite R12 online and batch processes can be initiated from a browser. For this benchmark, all runs used a browser to initiate the on-line user transactions and the batch processes were initiated as concurrent programs.

Figure 2 shows the configuration used for this benchmark run.

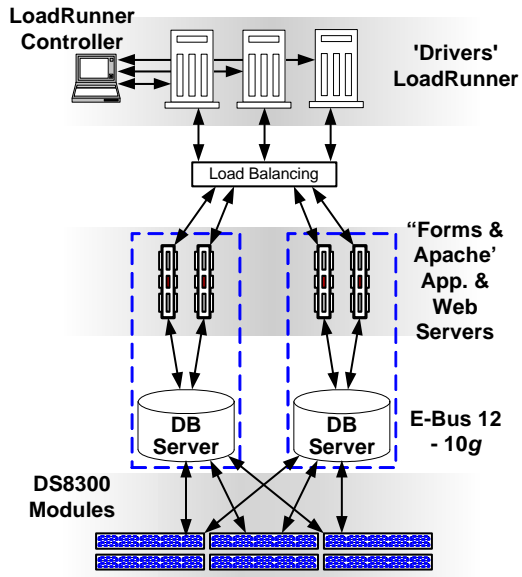

Figure 2: 3-Tier Configuration

This benchmark was run as a “Physical” 3-Tier configuration with discrete machines (partitions) hosting all of the Database and Application server instances.

SERVER PERFORMANCE

Server		Phys CPUs	User	Sys.	Wait	Idle
DB 1 (p5)	Avg	21.36	82.7	11.6	0.6	5.1
	Max	49.37	93.6	40.4	1.5	18.5
DB 2 (p5)	Avg	29.97	84.2	8.8	0.3	6.7
	Max	58.66	94.1	41.4	1.4	15.6
App. 1	Avg	1.74	18.6	57.8	0.0	23.7
	Max	5.40	54.0	67.2	0.0	37.4
App. 2	Avg	0.70	31.2	29.9	0.0	38.9
	Max	1.36	75.4	39.6	0.0	61.3

Table 2: Average Server CPU Utilization

Server	DB 1	DB2	App. 1	App. 2
Avg. GB Used	55.1	47.9	8.7	14.5

Table 3: Average Server Memory Utilization

DATA COMPOSITION DESCRIPTION

Major data components for the Telecommunications market model under test are summarized in the following table.

Telecommunications Scenario	Nominal
Customers	
No of Customers	42,000,000
No of Person Customers	42,000,000
No of Addresses Per Customer	1
No of Contacts Per Org	1
No of Contact Points Per Customer	1
No of Contact Roles Per Contact	1
No of Site uses Per Address	1
History months	4
History	
Number of direct debits	101,080,000
Number of cheques	14,905,800
Number of invoices	115,985,800
Embeddded Invoices	
Number of unpaid invoices (to be processed by direct debits)	2,515,800
Number of unpaid invoices (to be processed by lockbox)	88,200
Pickday Processing	
Daily inbound invoices	2,599,800
Daily inbound invoice Lines	27,455,400
Average number of lines per invoice	11
Daily outbound payments (Direct debits)	2,515,800
Daily inbound payments (Lockbox)	88,200
Invoices sent to dunning	37,800

Table 4: Data Composition

BATCH ROW COUNT GROWTH

Table Name	Rows	Rows	Rows
	History Data	History Data + Pick day 1 Run Data	Growth after running Pick Day 1
AR_PAYMENT_SCHEDULES_ALL	231,555,548	239,000,000	7,444,452
Transactions	115,777,774	121,000,000	4,950,484
Payments	115,777,774	118,000,000	2,493,967
GL_IMPORT_REFERENCES	1,303,571,336	1,400,000,000	96,428,664
Transactions	754,699,194	812,556,392	57,857,198
Payments	548,872,141	587,443,607	38,571,465
GL_JE_BATCHES	105,137	105,311	174
Transactions	52,568	52,655	87
Payments	52,568	52,655	87
GL_JE_HEADERS	132,460	132,634	174
Transactions	66,230	66,317	87
Payments	66,230	66,317	87
GL_JE_LINES	1,299,945,389	1,300,000,000	54,611
Transactions	752,599,962	752,632,728	32,766
Payments	547,345,426	547,367,271	21,844
XLA_AE_HEADERS	231,847,846	240,000,000	8,152,154
Transactions	115,923,923	120,000,000	4,076,077
Payments	115,923,923	120,000,000	4,076,077
XLA_AE_LINES	2,204,107,7060	2,300,000,000	95,892,294
Transactions	1,276,062,356	1,333,597,732	57,535,376
Payments	928,045,349	966,402,267	38,356,917
XLA_AE_SEGMENT_VALUES	39,642,735	122,000,000	82,357,265
XLA_DISTRIBUTION_LINKS	2,201,352,514	2,290,000,000	88,647,486
Transactions	1,274,467,244	1,327,655,736	53,188,491
Payments	926,885,269	962,344,263	35,458,994
XLA_EVENTS	232,562,083	240,000,000	7,437,917
Transactions	116,281,041	120,000,000	3,718,958
Payments	116,281,041	120,000,000	3,718,958
XLA_TRANSACTION_ENTITIES	232,852,542	240,296,993	7,444,451
Transactions	116,426,271	118,920,238	2,493,967
Payments	116,426,271	121,376,755	4,950,484
IBY_FND_CPT_TX_EXTENSIONS	248,727,090	255,000,000	6,272,910
Transactions	124,363,545	128,534,966	4,171,421
Payments	124,363,545	126,465,034	2,101,488
IBY_FND_CPT_TX_XE_COPIES	198,810,053	205,000,000	6,189,947
Transactions	99,405,026	103,521,278	4,116,251
Payments	99,405,026	101,478,722	2,073,695

Table 5a: Shared Transaction & Payment Table Growth

BATCH ROW COUNT GROWTH CONT.

Table Name	Rows	Rows	Rows
	History Data	History Data + Pick day 1 Run Data	Growth after running Pick Day 1
AR_CASH_RECEIPT_HI STORY_ALL	346,518,675	354,000,000	7,481,325
AR_CASH_RECEIPTS_ ALL	115,506,033	118,000,000	2,493,967
AR_DISTRIBUTIONS_A LL	923,564,522	944,000,000	20,435,478
AR_RECEIVABLE_APPL ICATIONS_ALL	346,032,624	354,000,000	7,967,376
IBY_EXTERNAL_PAYER S_ALL	40,103,020	40,220,007	116,987
IBY_FNDcpt_TX_OPE RATIONS	248,435	8,400,409	8,151,974
IBY_TANGIBLE	13,837,653	16,353,459	2,515,806
IBY_TRXN_SUMMARIE S_ALL	83,794	2,708,590	2,624,796

Table 5b: Payment Table Growth

Table Name	Rows	Rows	Rows
	History Data	History Data + Pick day 1 Run Data	Growth after running Pick Day 1
AR_DOC_SEQUENCE_ AUDIT	48,834	2,564,645	
RA_BATCHES_ALL	122	647	525
RA_CUST_TRX_LINE_G L_DIST_ALL	1,279,292,941	1,350,000,000	70,707,059
RA_CUST_TRX_LINE_S ALESREPS_ALL	0	0	0
RA_CUSTOMER_TRX_ ALL	116,049,516	121,000,000	4,950,484
RA_CUSTOMER_TRX_L INES_ALL	1,046,767,371	1,100,000,000	53,232,629
ZX_LINES	118,562,487	124,000,000	5,437,513
ZX_LINES_DET_FACTO RS	933,315,765	984,000,000	50,684,235
ZX_REC_NREC_DIST	28,567	28,567	0

Table 5c: Transaction Table Growth

GENERIC CONFIGURATION

Servers: IBM System p5-595 and P6-595

AIX5.3/POWER5 Features: During the benchmark, three specific features of AIX/POWER systems were used:

- The partitioning
- The micro-partitioning
- The Simultaneous Multi-Threading (SMT)

The micro-partitioning option keeps some CPUs in a general pool for both Application server and DB server to dynamically use in a 'shared-mode.'

Database: Oracle 10g (10.2.0.3) RAC

SGA	Size (Bytes)
Database Buffers	49,056,579,584
Fixed Size	2,135,936
Redo Buffers	64,970,752
Variable Size	19,595,790,464

Network: Gigabit full duplex. On the RAC interconnect network, an ether channel has been configured, providing a maximum bandwidth of 2 gbps. The Ether channel has been built without any network switch, using a point-to-point connection between the LPARs. The links for the storage was 6 x 4Gbps fiber channel.

APPLICATION TRAFFIC MANAGEMENT DEVICES:
1 x VLAN 81

All the LPARS (Logical Partitions) were configured with AIX 5.3 TL6 SP2 (5300-06-02-0727) using a 64-bits kernel, JFS2 system's file systems and ASM disk groups

BENCHMARK ENVIRONMENT

HARDWARE CONFIGURATION

Database Servers:

Two IBM System p5-595 servers were used as the database servers. The systems were equipped with the following:

- 54 × 2.3 GHz POWER5+™ processor chips (SMT-enabled), each with L2 Cache of 0,9 MB per core and L3 Cache of 18 MB per Core. (The Server actually has eight 8-Core modules [MCMs]. 54 cores were used for the database server and the remaining ten cores were used as a 10-core application server)
- Total Memory: 256 GB (~140 GB assigned)
- Storage: DS8300 75-T710 with 16 arrays of 300 GB each (Total 4.8 Terabytes.). Each array has 8 physical disks --- RAID 5, two. 128 GB memory cache

Operating system:

IBM AIX 5L V5.3 TL06

Application Servers:

See above.

10 × 2.3 GHz POWER5+™ processor chips (SMT-enabled), 36 GB assigned

For more details on System p5 595, please visit

<http://www-03.ibm.com/systems/p/hardware/highend/595/index.html>

For more details on DS8300, please visit

<http://www-03.ibm.com/systems/storage/disk/ds8000/index.html>

SOFTWARE VERSIONS

Oracle's E-Business Suite Applications R12 (RUP 3)

Oracle10g 10.X (64-bit) RAC

IBM AIX 5L for POWER V5.3 with the 5300-06-02-0727 Technology Level (on the database and Application /Web/CM servers) (64-bit)

Mercury Interactive's LoadRunner 8.0

For more details on Mercury's LoadRunner, please refer to <http://www.mercury.com/us/products/performance-center/loadrunner/>

Apache WebServer 1.3.19

Java™ 2 Runtime Environment, Standard Edition (build 1.4.2). Classic VM (build 1.4.2, J2RE 1.4.2 IBM AIX build ca142-20061124 (SR7) (JIT enabled: jite))

Citrix NetScaler NS7.0: Build 50.2, Date: Jan. 31, 2007

Glossary and Acronyms:

RAC Real Applications Clusters



ORACLE

Oracle

Applications Performance & Benchmarks

500 Oracle Parkway

Redwood Shores, California 94065

Tel 650/506-7000

Fax 650/506-7000

Email eBKit_us@oracle.com

World Wide Web <http://www.oracle.com>

E-Business Suite, AppsNet, Collaboration Suite, Oracle Direct and RAC are trademarks of Oracle, Inc. Oracle, JD Edwards, PeopleSoft and Siebel are registered trademarks of Oracle Corporation and/or its affiliates. Other names may be trademarks of their respective owners. The information contained herein is subject to change without notice. Copyright © 2008 Oracle, Inc. All rights reserved. C/N 0XXX-0608 Results Registration Number: 0XXX

©2008 IBM, Inc. All rights reserved. IBM, and the IBM logo are trademarks or registered trademarks of IBM, Inc. in the United States and other countries.