

Business Process-Centric System Design

*An Oracle White Paper
April 2009*

Note:

The following is intended to outline our general product direction. It is intended for information purposes only, and may not be incorporated into any contract. It is not a commitment to deliver any material, code, or functionality, and should not be relied upon in making purchasing decisions. The development, release, and timing of any features or functionality described for Oracle's products remains at the sole discretion of Oracle.

Table of Contents

Introduction	4
The Business Process-Centric System Lifecycle	5
Comprehensive End-to-End Lifecycle	5
The Value of Business Process During All Phases of the Business	
Process-Centric System Lifecycle.....	6
Idea and Concept.....	6
High-Level Conceptual Design and Scope	6
Conceptual Design with Roles.....	7
Functional Design.....	8
Technical Design.....	9
Build.....	10
Test	11
Implement.....	12
Maintain and Support.....	13
Train.....	13
Deploy, Manage, Simulate, and Reengineer.....	13
Governance.....	13
Execute.....	14
Upgrade.....	14
How Can Oracle Help?	15
Oracle Business Process Analysis Suite	15
Delivered Business Process Models.....	15
Conclusion.....	16

Business Process-Centric System Design

...the major challenge for managers is to obliterate non-value adding work, rather than using technology for automating it.

-Michael Hammer 1990

INTRODUCTION

Too often human needs get overlooked in system design. The focus is on technology--architecture, components, modules, interfaces, and data--all of which are important and costly to get wrong. But also important is what the humans need to do and their ultimate objectives.

It is universally recognized that in order to survive, an enterprise needs to be efficient, economical, flexible and lean. Much of this can be accomplished with sheer technology, but the needs and objectives of the humans are still paramount. Humans make the strategic, innovative and creative decisions that technology must support.

The single best context for accomplishing business objectives is within the business process. Business process allows the enterprise to structure what needs to be done in a paradigm that allows for management, control and visibility in a context easily and naturally understood by humans. Who does what when? What happens next? Where do concurrent sequences of events split and converge? Where are critical decision points and what rules are followed?

Business process-centric design can be used throughout the entire system lifecycle to result in optimum business process centric systems.

THE BUSINESS PROCESS-CENTRIC SYSTEM LIFECYCLE

Comprehensive End-to-End Lifecycle

If business systems are truly based on business process-centric design, then the influence and natural human understanding of business process can be leveraged all throughout the system lifecycle. From idea through concept, design, build, test, implementation and post-implementation, the business process context will provide systems that allow for maximum human comprehension and usability.

The most profound lesson of business process reengineering was never reengineering, but business processes. ...

For technologists, the lesson from reengineering is a reminder of an old truth: information technology is only useful if it helps people do their work better and differently.

-Thomas H. Davenport 1995

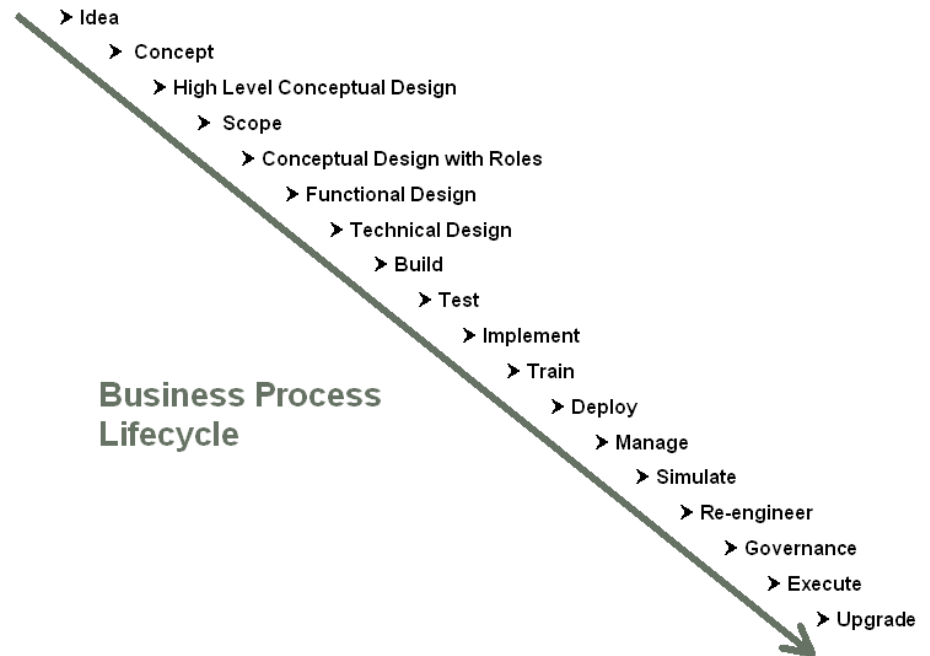

Figure 1: Business Process-Centric System Lifecycle

THE VALUE OF BUSINESS PROCESS DURING ALL PHASES OF THE BUSINESS PROCESS-CENTRIC SYSTEM LIFECYCLE

Idea and Concept

During the idea phase of the lifecycle, it is important to consider the new idea or enhancement within the context of the business process. This forces the designer to be constantly aware of the broader business process and the possible impact of the new idea on concurrent processes, and upstream and downstream processes. In the case of the enterprise with multiple variations of a business process, it also forces an awareness of the economies and efficiencies that can be accommodated by a global or service-oriented enhancement. So thinking of the new idea within its broader context ensures a more comprehensive solution than a spot solution.

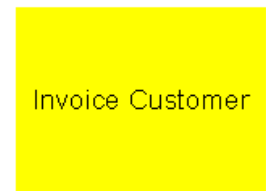
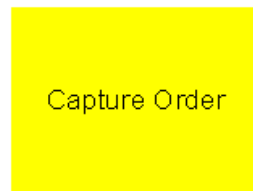

Figure 2: Idea and Concept Phases of the Business Process-Centric System Lifecycle

High-Level Conceptual Design and Scope

During high-level conceptual design, it is important to think of what is happening and not how. This is the opportunity to capture a high-level conceptual understanding of what the humans want and need to happen to allow them to accomplish their objectives. Whether or not it is technically feasible at the present time, it is still important to capture the various desirable options in order to facilitate future or phased design implementations. Often a non-feasible option becomes feasible in a subsequent design cycle but the conceptual thinking about the idea has been lost. Fully considering all options ensures more comprehensive and global consideration when defining scope.

The needs of the business are reflected primarily in the organization's business processes, and thus one would think that SOA must have a business process-centric perspective. But all too often ... consulting firms, and technology vendors focus not on those business processes, but rather on the underlying technology platforms, standards-based interfaces, and system-to-system communication. Indeed, the story of business process has been at times so buried within the discussion of SOA that to the business, SOA itself has no business relevance. And yet, if there is any hope to a long-lasting impact and benefit of SOA, it must indeed be business relevant, and thus business process-driven.

-Ronald Schmelzer 2007

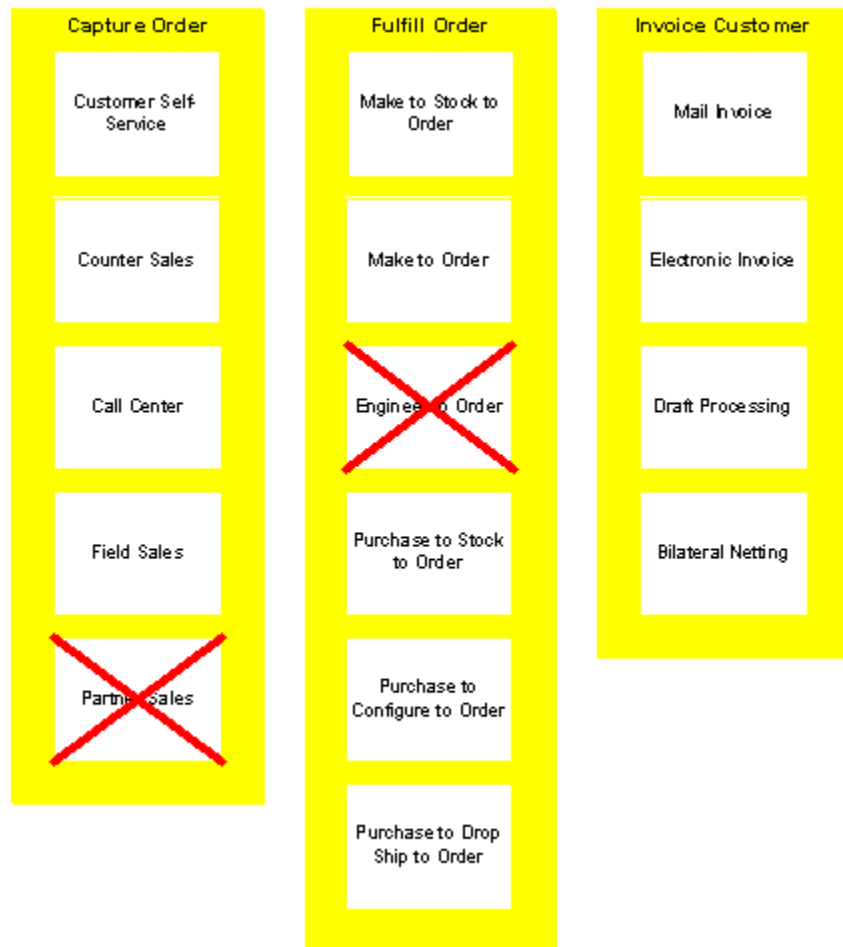

Figure 3: High-Level Conceptual Design and Scope Phases of the Business Process-Centric System Lifecycle

Conceptual Design with Roles

As the conceptual design matures, it is important to capture the conceptual business process steps and the business roles that participate in the process. This step captures the early influences on user interface design and user access security design. The logical steps a given role performs should be considered heavily in the user interface design and can help determine how many screens or fields of information may be required to be entered by the performing role. The conceptual model also allows visibility into the business intelligence that may be required by the performing role. So if the triggering events and objectives of the business process are clearly seen and considered, the supporting system design can be better informed by this visibility resulting in better logical design.

The roles and the steps they perform are also valuable in designing user access security. It is a perfect use of role-based workflow business process models to capture the business analyst's intent for user access control. Physical implementation of this user access control design can manifest in many ways. But the business intent can be seen quite clearly in this type of model. Separation of

duties is also clear and can be corrected in the design before development actually takes place as well. This is a very important design phase and can save much rework downstream if analyzed carefully.

This level of detail should become part of the business requirements document.

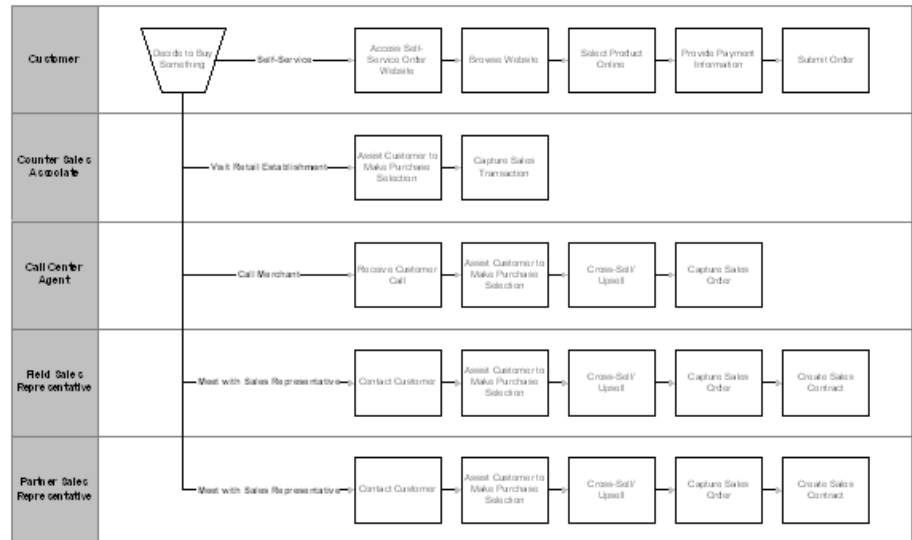

Figure 4: Conceptual Design Phase of the Business Process-Centric System Lifecycle

Functional Design

Functional design is a refinement of the conceptual design with more detail and elements added at this point. The conceptual design is broken down into functional components and enhanced with references to the actual components planned for development. Process integration points should also be added for awareness of how this process fits into the broader enterprise-wide business process context. Enterprise business objects and services should also be apparent at this level of granularity and should be referenced on the models as well. This establishes a linkage of the conceptual business intent to the early functional design in order to ensure that what is intended is what actually gets designed.

This level of detail should become part of the functional design document and should maintain close correspondence with the actual functional components under design.

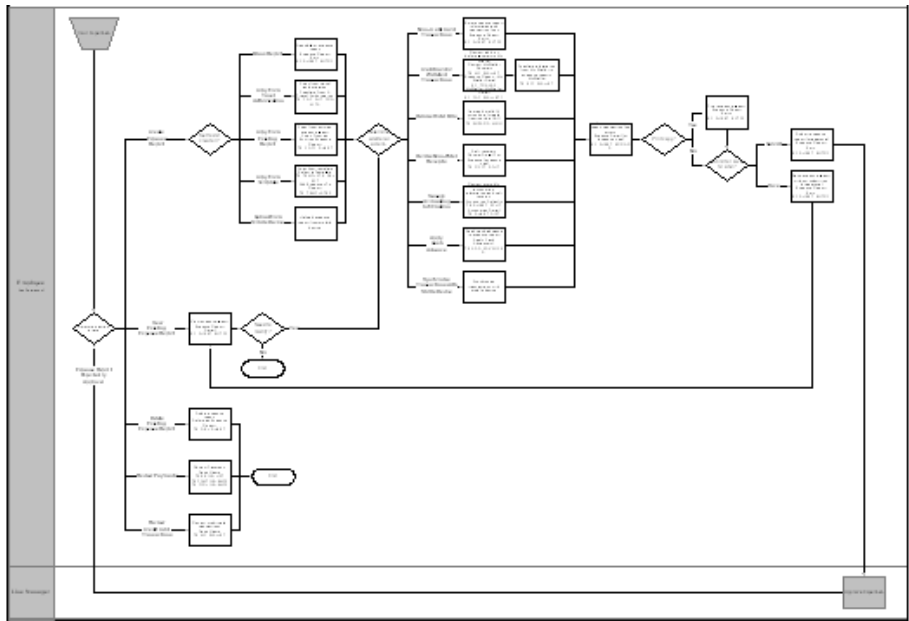

Figure 6: Technical Design Phase of the Business Process-Centric System Lifecycle

Build

During the build phase, changes in design should be updated on the models to reflect what is actually built. The business analyst should review these changes closely to ensure that the original design intent does not get changed.

Documentation that describes the as-built systems is also finalized at this point and can be organized within a business process framework. Associated release documents, marketing and sales collateral, and field readiness messaging and content should also be organized in this way. So all functional descriptions of the systems can be framed within the business process context to ensure a consistent paradigm of delivery to business users.

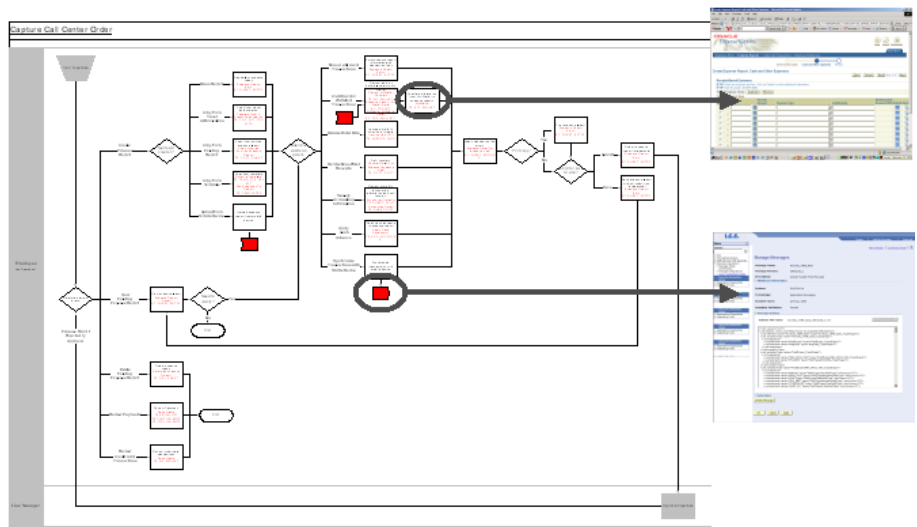
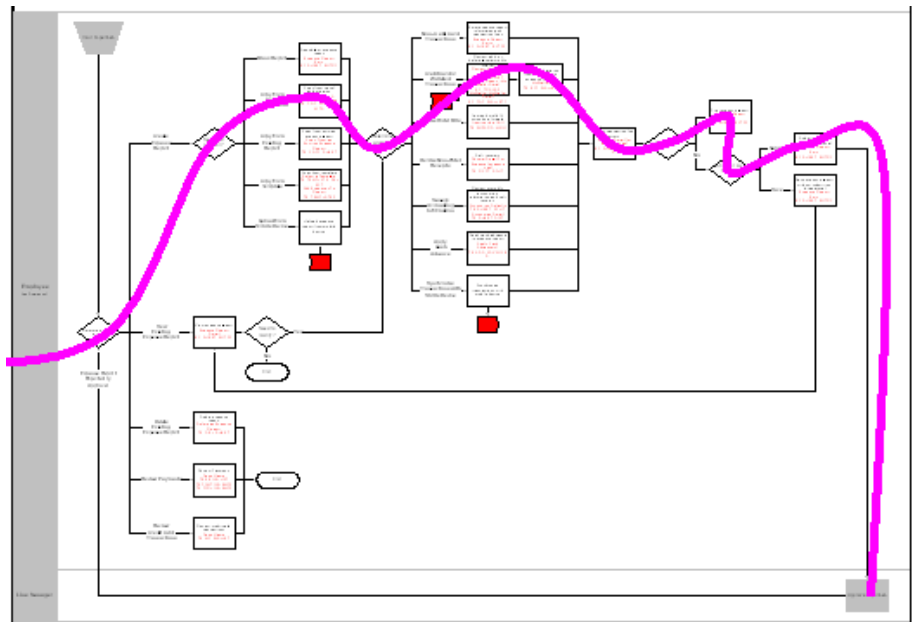

Figure 7: Build Phase of the Business Process-Centric System Lifecycle

Test

The models created during the previous phases and revised as necessary to reflect any changes can be used to establish and communicate test scenarios during the system test phase. There may be many integration test scenarios and the business analyst can use the models as a foundation to convey those scenarios that should be tested, and then regression tested if necessary later. These models will help the QA teams to establish their high-level test scenarios to which they will add detailed test scripts and data. These models are also valuable in creating automated test procedures and scripts.



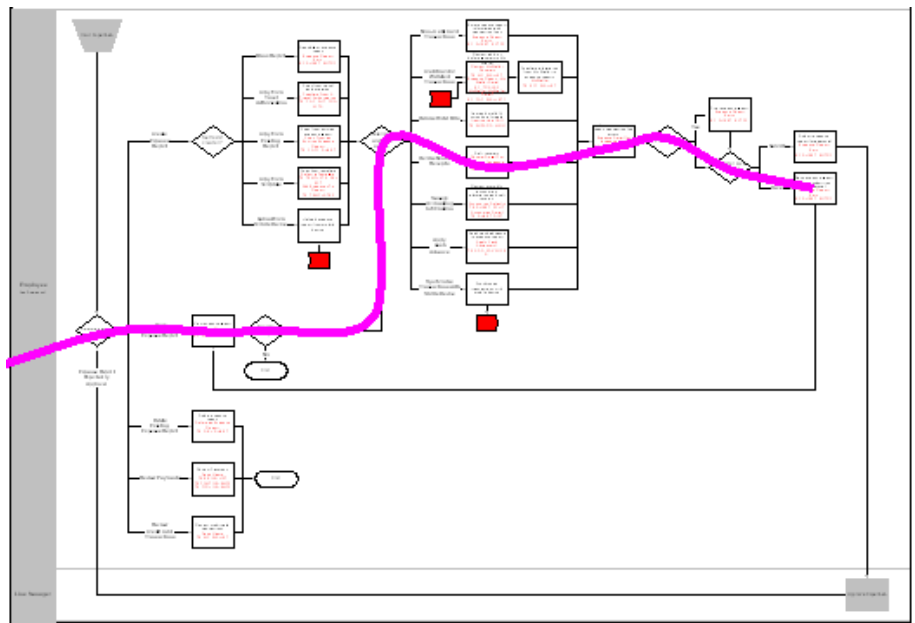

Figure 8: Test Phase of the Business Process-Centric System Lifecycle

Implement

During the implementation phase, the models can be updated to reflect which features and functionality were actually implemented. For a phased implementation, this is important so that the business analyst can quickly understand what is supported by the implementation and what is not.

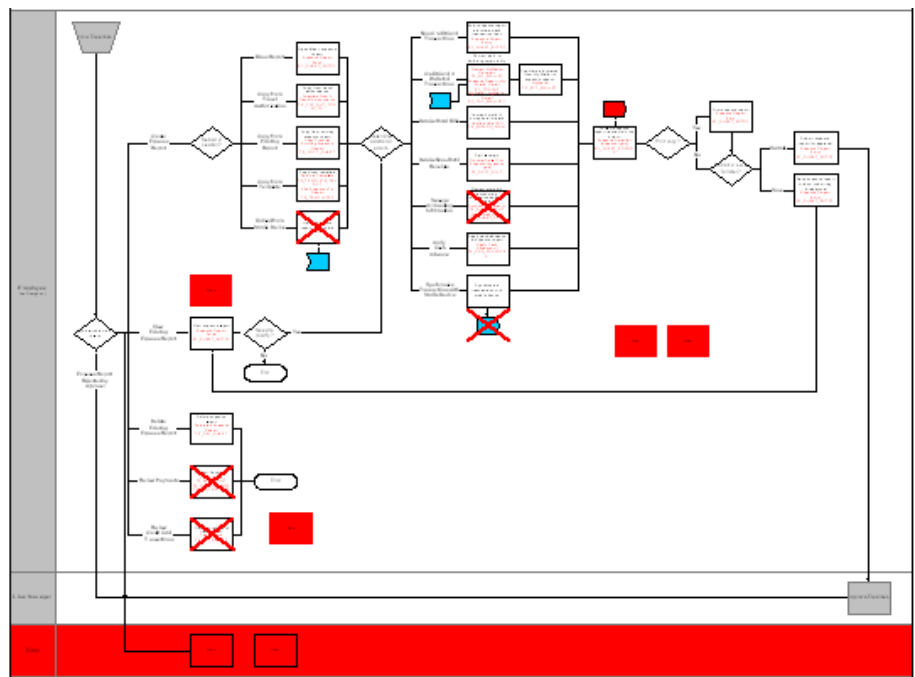

Figure 9: Implement Phase of the Business Process-Centric System Lifecycle

Maintain and Support

Issues and support activities can be captured and tracked by business process as well as by system. This allows visibility into the problems a given business process may experience regardless of how many systems are supporting that process.

Train

These same models are invaluable in training end users and mapping functionality to corresponding desk manuals and procedures, contextual help, or recorded transactional training and performance support tools.

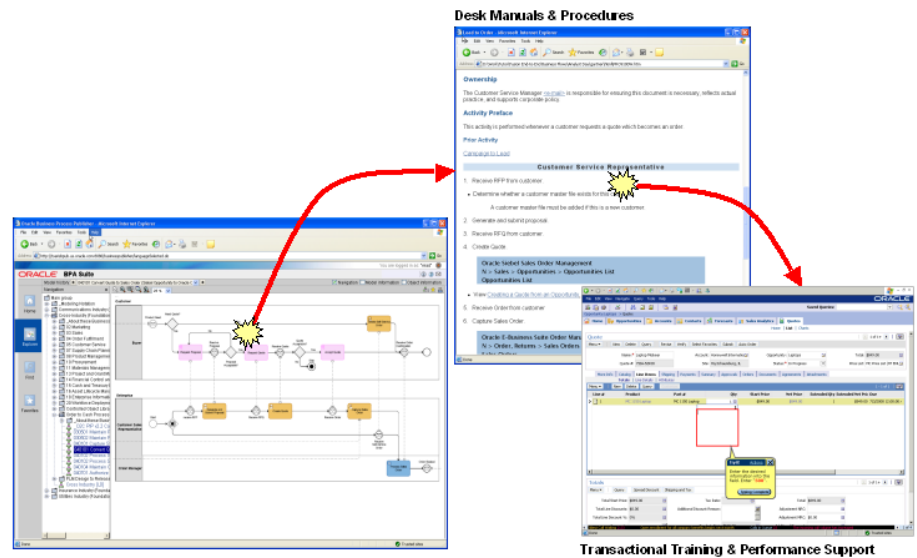

Figure 10: Train Phase of the Business Process-Centric System Lifecycle

Deploy, Manage, Simulate, and Reengineer

The implemented business process models are invaluable as well for communication and understanding business processes during operations. They can be used to analyze what is actually happening in order to fine-tune or reengineer a process. They can also be used with automated tools to simulate alternate scenarios to improve and optimize a process.

Governance

The implemented business process models are also valuable in analyzing and documenting internal control points, risks, and key performance indicators required to ensure business process governance and compliance with governing authorities. A compliance auditor will often create this type of business process model in order to understand the processes in operation before they begin the required compliance audit.

HOW CAN ORACLE HELP?

Oracle Business Process Analysis Suite

Oracle Business Process Analysis Suite provides comprehensive modeling, analysis and simulation capabilities for enterprise-wide business process management. Oracle BPA Suite supports Enterprise Architecture, process improvement and change management initiatives, and provides for alignment of Business Process Management (BPM) and Service-Oriented Architecture (SOA) initiatives. In addition, Oracle BPA Suite is innovatively integrated with Oracle SOA Suite to provide closed-loop BPM capability, enabling business analysts and developers to closely collaborate throughout the entire BPM lifecycle using the best tools for their specific needs.

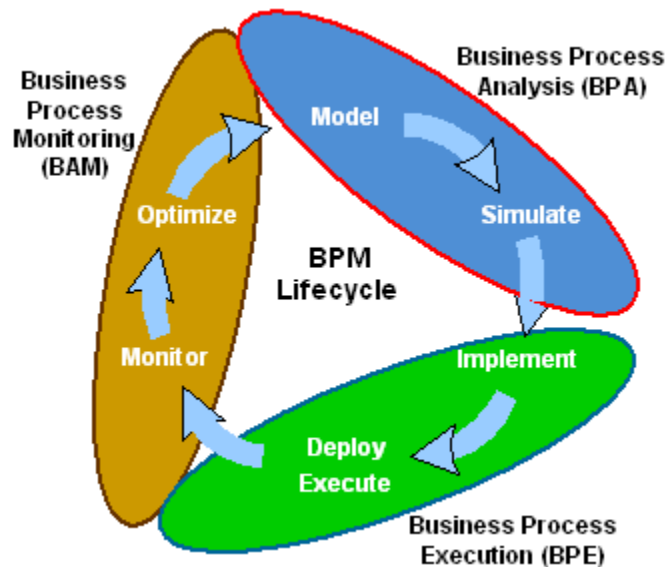

Figure 12: Business Process Management (BPM) Lifecycle

Delivered Business Process Models

Oracle helps accelerate your system design, implementation and upgrade projects by delivering a library of pre-built business process models that you can start with. Several types of models are delivered, including:

- Reference Process Models (RPM) – Horizontal, functionally scoped business process models that depict all of the aspects of the processes supporting a particular function (Marketing, Sales, and Order Fulfillment, for example).
- Industry Business Process Models – Industry-specific business process models that combine industry processes with relevant horizontal processes and variations of horizontal processes.
- Composite Business Flows – End-to-end processes that are comprised of parts of several functional business processes (Order to Cash, Procure to Pay, and Design to Release, for example).

CONCLUSION

Business process-centric system design can ensure that your systems are designed and built to accommodate the needs and intent of the business users. This business process focus is important throughout the entire system lifecycle, from concept to deployment, and forces a continuous awareness on the part of all participating in the development process of the business objectives.

What needs to happen, when, and by whom is considered in lockstep with how it is happening. The systems are designed to support what the humans need to reach the ultimate business objective. Technology will change over time, but the conceptual business processes will not. Oracle has both the tools and the process intelligence to help you manage both the technology and the human requirements for your business process-centric system design.



White Paper Business Process-Centric System Design

April 2009

Author: Pat Krebs

Oracle Corporation
World Headquarters
500 Oracle Parkway
Redwood Shores, CA 94065
U.S.A.

Worldwide Inquiries:

Phone: +1.650.506.7000

Fax: +1.650.506.7200

oracle.com

Copyright © 2009, Oracle and/or its affiliates. All rights reserved.

This document is provided for information purposes only and the contents hereof are subject to change without notice.

This document is not warranted to be error-free, nor subject to any other warranties or conditions, whether expressed orally or implied in law, including implied warranties and conditions of merchantability or fitness for a particular purpose. We specifically disclaim any liability with respect to this document and no contractual obligations are formed either directly or indirectly by this document. This document may not be reproduced or transmitted in any form or by any means, electronic or mechanical, for any purpose, without our prior written permission.

Oracle is a registered trademark of Oracle Corporation and/or its affiliates.

Other names may be trademarks of their respective owners. 0408