

ORACLE®



ORACLE
OPEN
WORLD

Your. Open. World.

Deploying High Availability with Oracle VM

Rick Cote
Systems Architect
University of
Massachusetts

Kurt Hackel
Senior Dev. Manager
Oracle VM

Richard Exley
CMTS
Oracle Dev. MAA

Session Outline

- Introduction
- Physical Environment
- Oracle VM Server
- Oracle VM Manager
- Guest VM High Availability
- Q & A

Introduction



University of Massachusetts

- The University of Massachusetts has been providing a high quality education environment for students & faculty from Massachusetts and from all over the world for more than 140 years.
- More than 75,000 students and faculty serviced by shared ERP service (HCM; FIN; SA; BI)
- 5 Campus System & President's Office
- UMass Online is one of the largest single on-line infrastructures with 30,000 students enrolled with over 6,000 concurrent sessions during peak times.

Maximum Availability Architecture (MAA)

Maximum Availability = Unbreakable Architecture + Best Practices

- **Oracle's best practices blueprint** based on proven Oracle high availability technologies and recommendations
 - Technology + Configuration + Operational Practices
 - Applications, Enterprise Manager, Application Server, Collaboration Suite and Database
 - Constantly validated and enhanced as new products and features become available
 - Focused on reducing unplanned and planned downtime
- Papers published to the Oracle Technology Network (OTN)
 - <http://www.oracle.com/technology/ deploy/availability/htdocs/maa.htm>

Physical Environment



Physical Environment

HA Considerations

- Physical Security
- Power
 - Utility Supply
 - Generators
 - Battery backup
 - Power Distribution
 - Power supplies
- Cooling
 - Air conditioning
 - Fans

Oracle VM Server

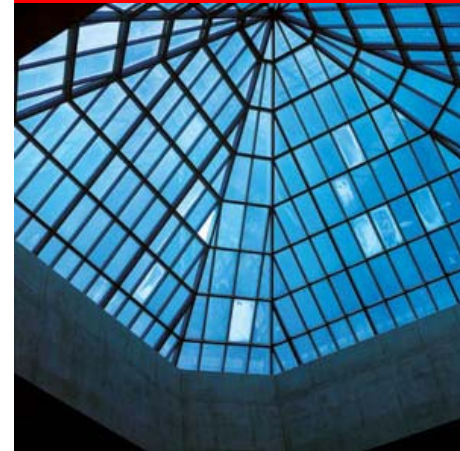

Oracle VM Server

HA Considerations

- Network/NAS
- SAN
- Server Pools

Oracle VM Server

Network/NAS: Redundant NICs and Switches

- Install redundant NICs for each network on each server
- Ideally, configure redundant switches
- Configure NIC Bonding
 - Active/Passive for switch redundancy
 - Active/Active to single switch – 802.3ad
 - See: Support Note 738269.1
- If configured in Domain-0, all VMs take advantage of the redundant network configuration, or configure in each VM if required

Oracle VM Server

University of Massachusetts

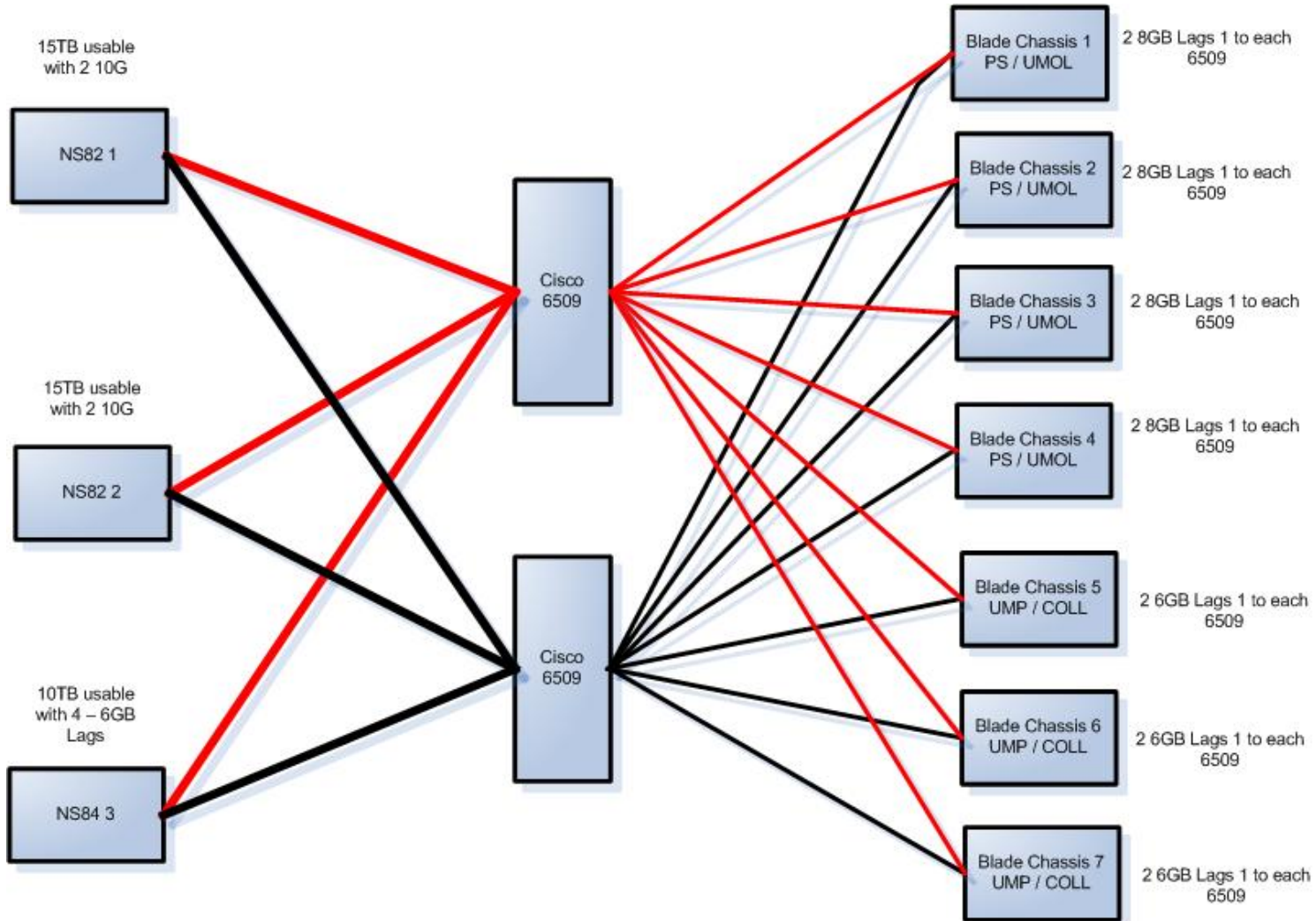

Oracle VM Server

University of Massachusetts

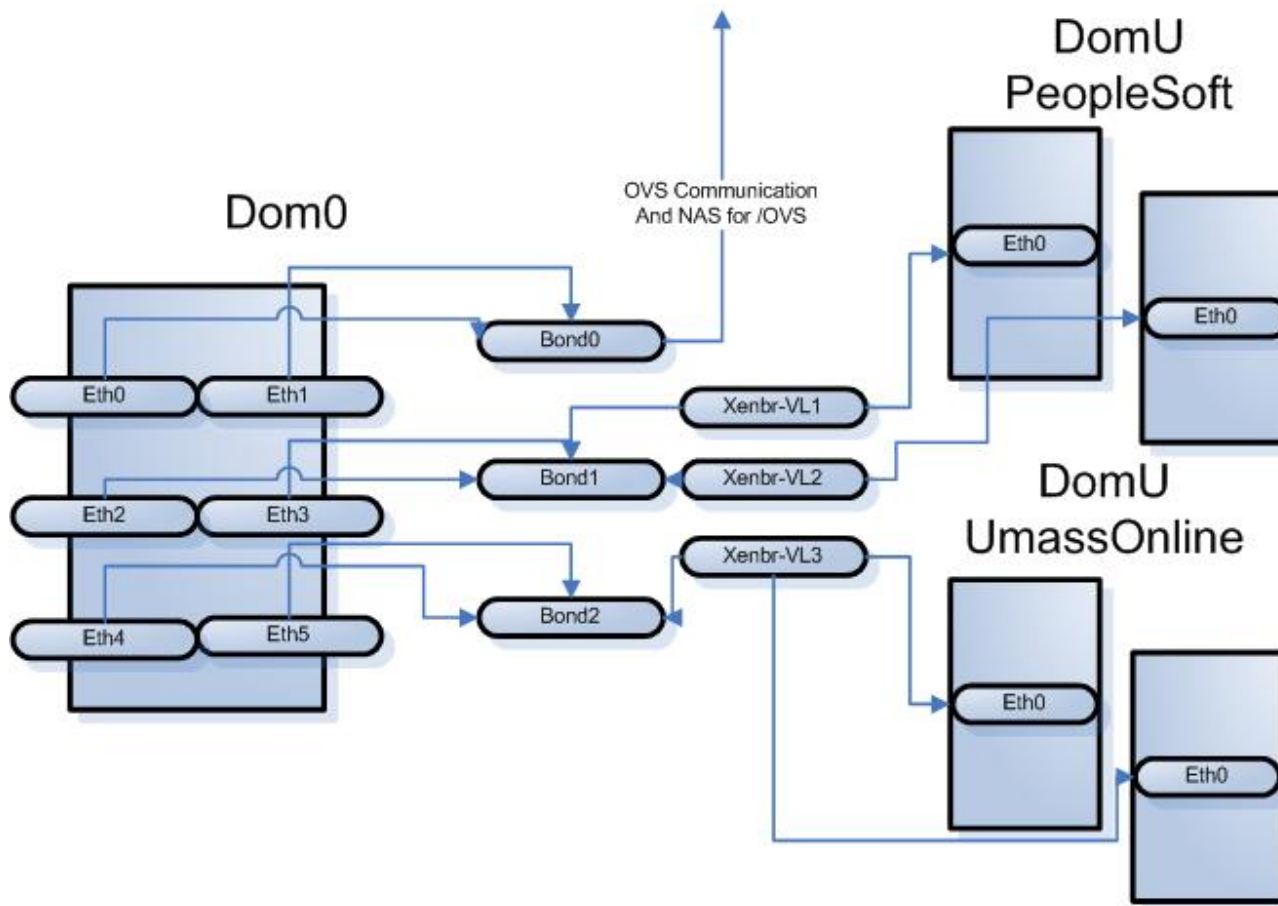

Oracle VM Server

SAN: Multipath

- Install multiple HBAs and setup multiple paths to the LUNs
- Install Oracle VM with multipath support (md-multipath)

```
boot: linux mpath
```

- Configure shared file system on /dev/mapper/...
- If configured in Domain-0, all VM's gain advantage, or run dedicated LUNs per VM if required
- Oracle VM 2.1.2 also supports RDAC

Oracle VM Server

MAA Lab – HP C3000 Blade Server - Ethernet

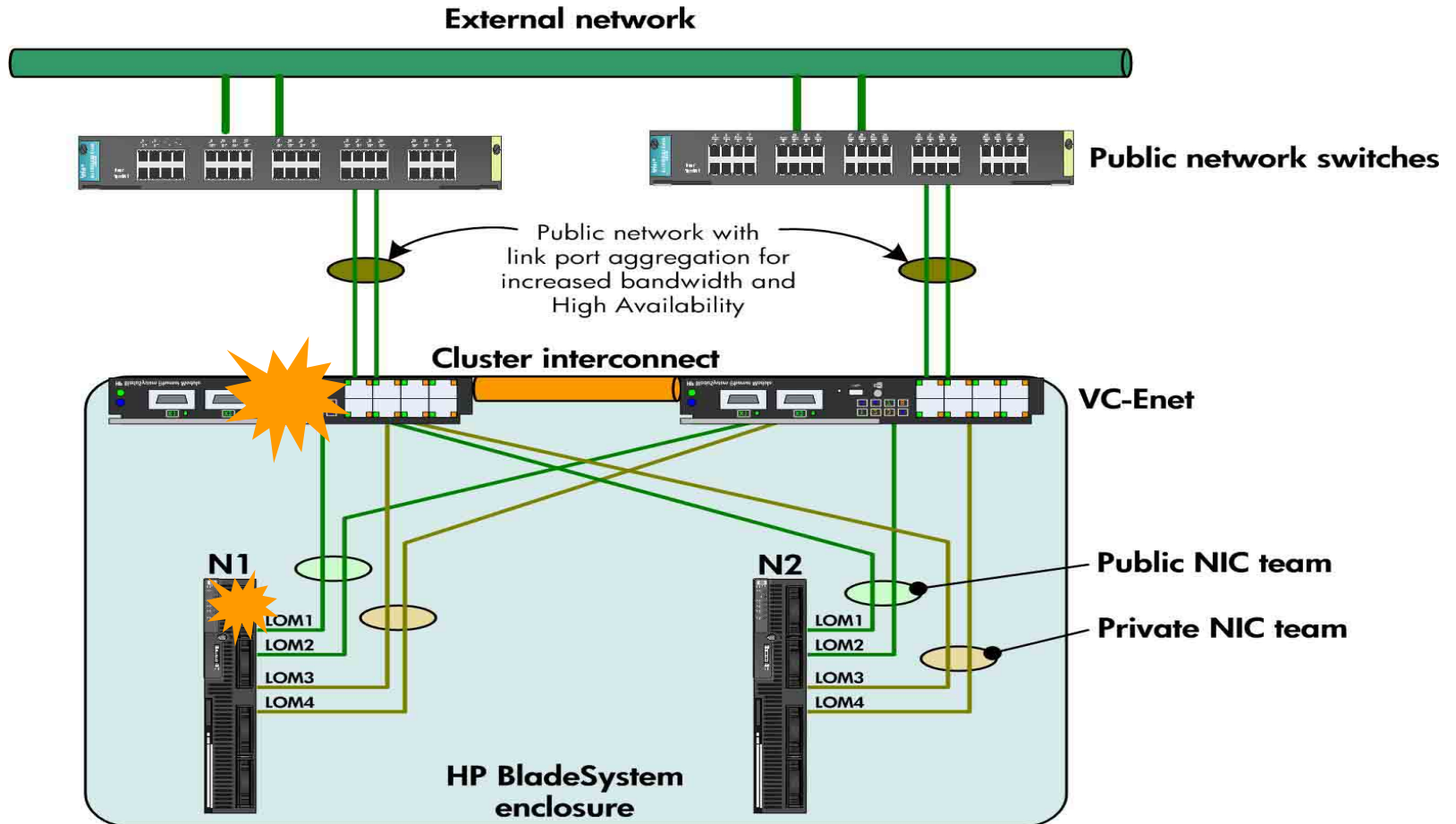

Oracle VM Server

MAA Lab – HP C3000 Blade Server – SAN

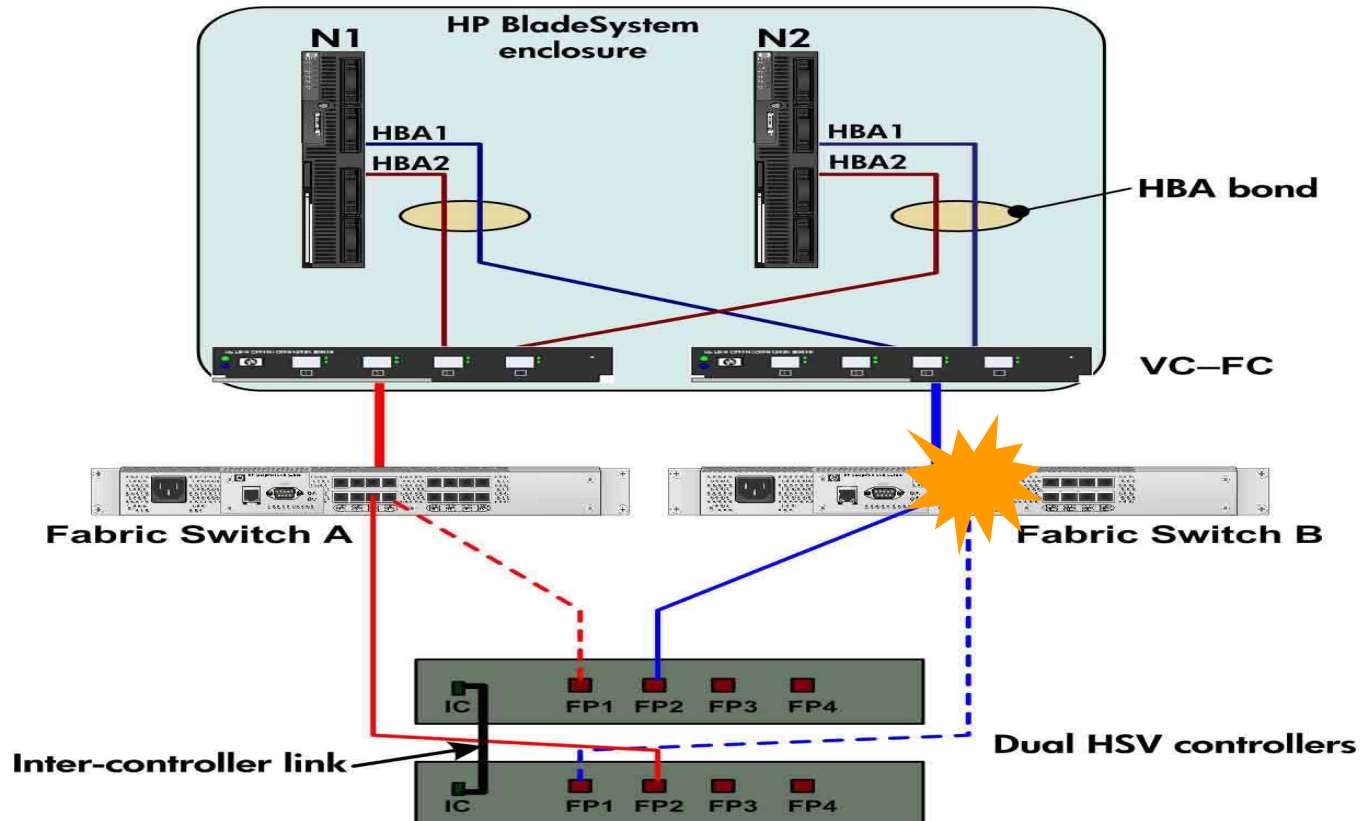

Oracle VM Server

MAA Lab Tests

- Siebel 8.0.0.2:
 - Database 11.1.0.6
 - OEL Release 4 Update 5 VM
 - Oracle VM 2.1.2
- Three test cases:
 - “ifdown” primary network interface
 - Power-off the active network switch
 - Power-off a fiber channel module (HBA disconnection)
- No apparent interruption in Siebel Online Service in all cases

Oracle VM Server

Server Pool Considerations

- Multiple VM servers per pool
 - Allow headroom to absorb single server failure
- Multiple utility servers per pool
- For maximum availability, run a dedicated pool master
 - Pool master recovery paper to be published shortly

Oracle VM Server

University of Massachusetts



Oracle Virtual Manager

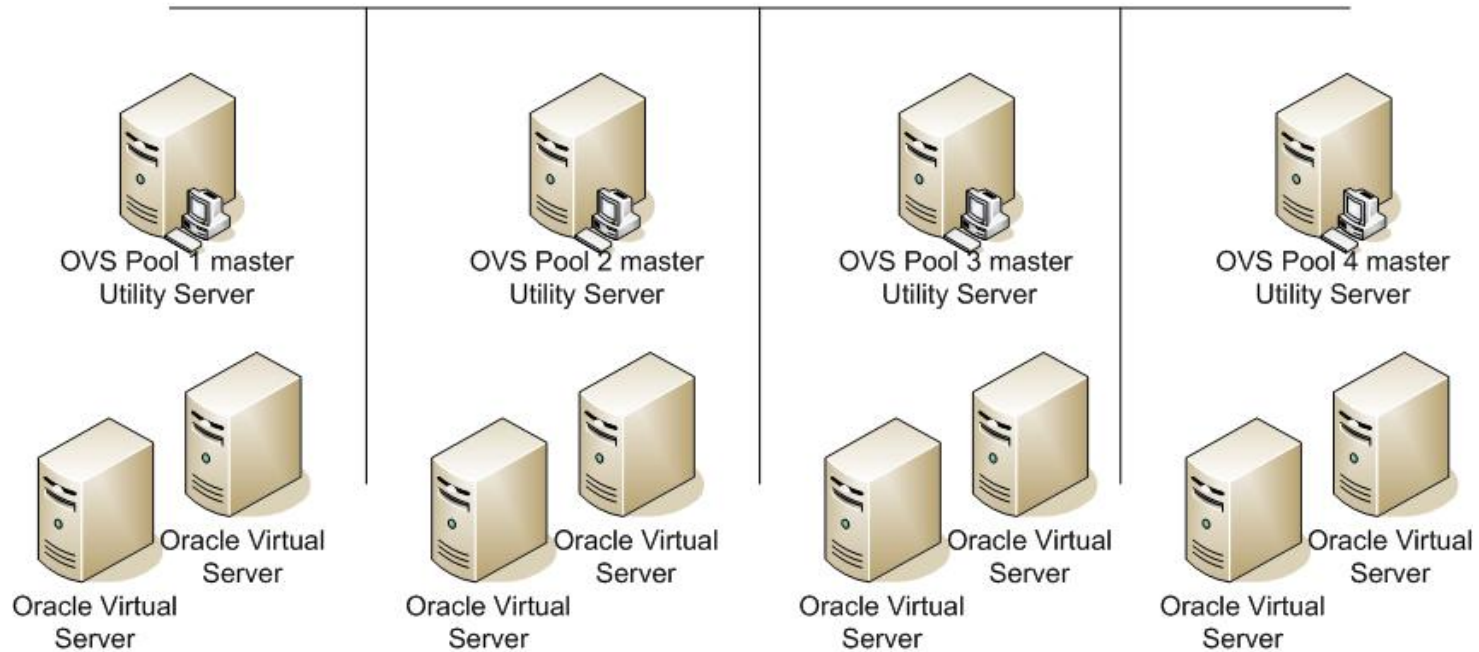

Oracle VM Server

Useful Platform Feature - HP Virtual Connect

- Virtual Connect Server Profile virtualizes MAC address and WWN
- Combined with SAN boot enables:
 - Rip and Replace - replace blade server without reconfiguration
 - Profile Migration - move server identity profile to another blade
- Particularly useful for pool master recovery

Oracle VM Manager



Oracle VM Manager

HA Options

- Clustered Active/Passive with automatic failover
 - Oracle Clusterware
 - Automatic-restart
 - Oracle VM Manager clustering paper to be published shortly
- Deploy within VM in server pool
 - Manual restart
 - Uses VM Server hardware and simpler to configure
- Note, VMs continue running when VM Manager is down

- Note as of 2.1.2, the VM Manager database can run on an external database server

Oracle VM Manager Cluster Failover

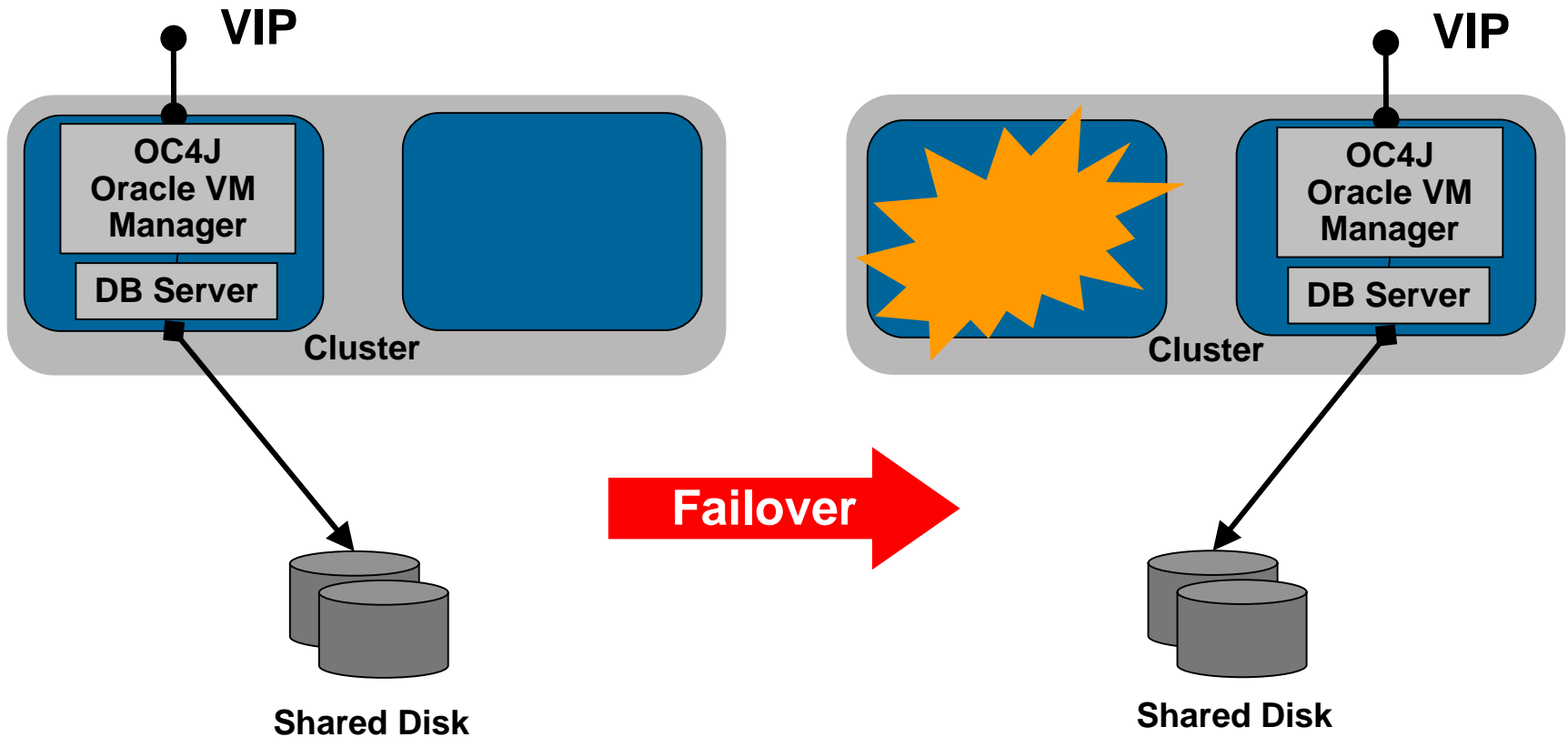

Guest VM High Availability

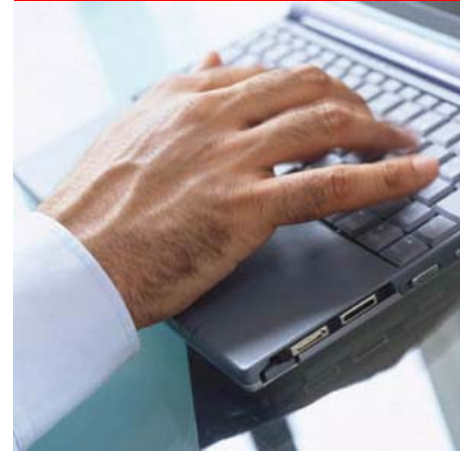

Guest VM High Availability

Oracle VM 2.1.2 Features

- Automatic restart of failed VMs across the pool
 - Server failure (all VMs restarted)
 - Individual VM failure
- Reliable restart based on proven Oracle Clusterware technology
 - Sophisticated heartbeat and lock management
 - Reliable failure detection and corruption prevention
- Maximize up-time without complexity of traditional HA clustering
 - Cost-effective solution
 - No guest VM agents or modifications required

Guest VM High Availability

Complete Solution

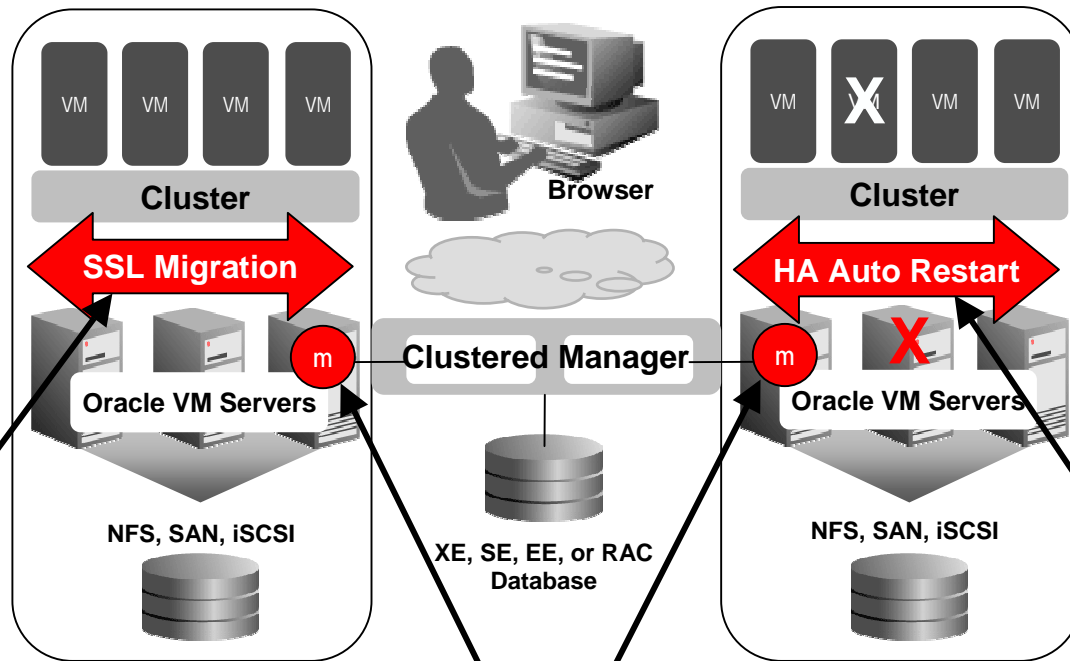

Planned Events:

- E.g. maintenance or upgrades
- Secure Live Migration
- Zero interruption

Pool Masters assure Secure Migration or HA restarts complete in the event of a Manager outage

Unplanned Events

- E.g. Server or VM failure
- HA Auto-restart in pool
- No manual intervention

Guest VM High Availability

Secure Live Migration - Uninterrupted Service

- Industry First:
 - Encrypted Live Migration by Default
 - No additional hardware required
 - Eliminates requirement for dedicated network
- Other products migrate VM data in the clear
 - Requires dedicated network
 - Leaves sensitive data vulnerable (passwords, account numbers, etc.)
- More secure, more flexible

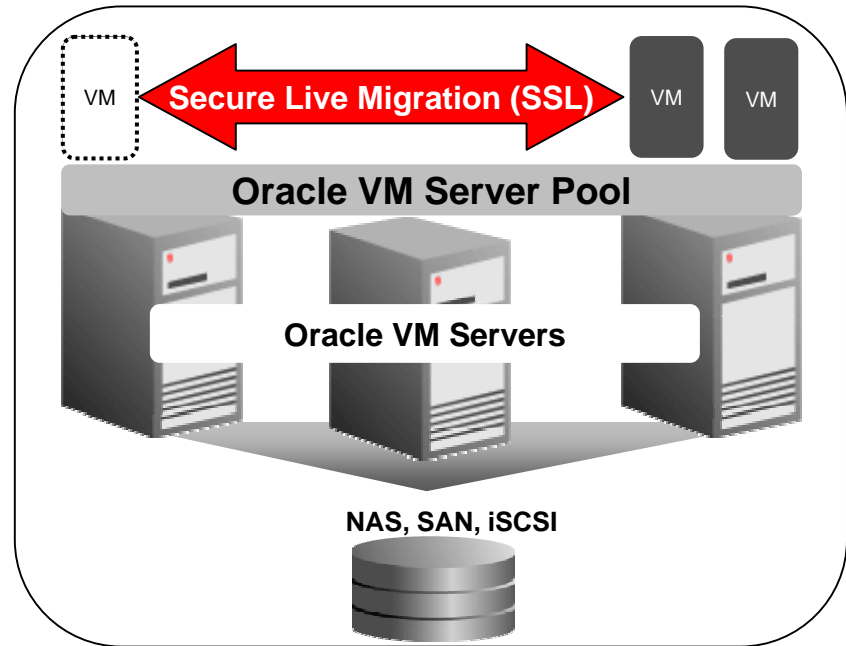

Q & A



HA Sessions, Labs, Demos From Oracle Development

Mon, Sep 22

- 2:30 pm - Database 11g: Next-Gen HA, Moscone South 103

Tue, Sep 23

- 9:00 am - Active-Active Data Centers, Moscone South 103
- 11:30 am - Sharding with Oracle, Moscone South 305
- 11:30 am - HA with Oracle VM, Moscone West 3024
- 1:00 pm - Active Data Guard, Moscone South 104

Wed, Sep 24

- 9:00 am - Fusion Middleware Grid HA, Marriott Nob Hill AB
- 11:30 am - RMAN Best Practices, Moscone South 103
- 5:00 pm - Data Guard & Real Application Testing, Moscone 102
- 5:00 pm - EM in Secure MAA, Moscone West 2001

Wed, Sep 24 (contd.)

- 5:00 pm - E-Business Suite HA, Moscone West 2002/04

Thu, Sep 25

- 9:00 am - Oracle Secure Backup, Moscone South 102
- 10:30 am - Streams Replication, Moscone South 102
- 12:00 pm - Rolling Database Upgrades, Moscone South 103
- 1:30 pm - Streams Performance, Moscone South 102
- 3:00 pm - Oracle Grid Computing, Moscone South 303
- 3:00 pm - E-Business Suite R12 MAA, Moscone West 2007
- 3:00 pm - Siebel MAA, Moscone South 308
- 3:00 pm - Fusion SOA HA & Scalability, Marriott Salon 14/15

Hands On Labs - Thu, Sep 25

- 10:30 - 11:30 am, 12:00 - 1:00 pm - Active Data Guard, Marriott Golden Gate A3

DEMOgrounds, Mon-Thu

- Active Data Guard, Streams, Oracle Secure Backup, RMAN/Flashback, MAA

Resources

- **Oracle VM Home Page**
oracle.com/virtualization
- **Free Download: Oracle VM**
edelivery.oracle.com/oraclevm



For More Information

search.oracle.com

virtualization



or

oracle.com

ORACLE®