

Oracle Communications Elastic Charging Engine

Increasing mobile broadband usage from smart phones, IoT devices and expanding ecosystems are changing data consumption behavior and the way businesses operate. Charging for service and data usage requires real-time processing with instant and personalized customer notifications, network slice and policy-based services, and hybrid prepaid and postpaid charging plans. The cloud native Elastic Charging Engine redefines real-time charging with extreme performance, inherent high availability, dynamic scalability and low cost, efficient operations.

Ready for hyperscale charging demands

Oracle Communications Elastic Charging Engine (ECE) is an online and offline converged charging system (CCS) with integrated 5G charging function (CHF) at the heart of Oracle’s Cloud Scale Monetization portfolio. Powered by industry leading in-memory grid technology, ECE has been designed to support the technical and business monetization demands for techco communication service providers (CSP). It is a digital experience engine for the 5G era, providing 3GPP aligned real-time converged data and communications session charging and balance management, with native integration into Oracle’s full suite of monetization capabilities designed in accordance with TM Forum principles.

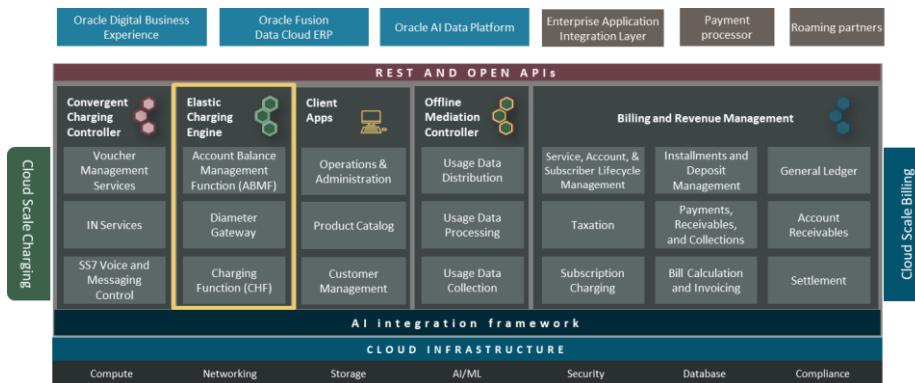

Image 1. Key functions provided by ECE within Oracle’s Cloud Scale Charging and Billing solution.

Core network integration

Built around network and IT industry standards, ECE uses an innovative high performance and coherent data management architecture to support near linear scalability, low latency, and highly available multi-site deployments with full transactional consistency. ECE supports converged charging architecture in both

“With a modular, pre-integrated stack, we avoid the costly and time-consuming process of complex integrations and high level of customizations. This means we can launch, orchestrate, and monetize new offerings as the market demands while delivering an excellent experience for our customers in the process.”

Ahmed Al-Anqari
CEO, Salam

Key benefits

ECE provides unmatched performance and functionality with extremely low total cost of ownership:

- Prepaid and postpaid charging for all services on a single system.
- Charge for anything at any scale with rapid time to market
- Network grade performance and cloud scale operational experience
- Cloud native agility to deploy services more quickly, operate more efficiently, and scale as business needs grow.
- Engineered options to meet gold standard business continuity needs.

Verified large scale performance

Single-digit millisecond latency and large-scale TPS across dual-site deployments is demonstrated in a [performance test report for 100 M subscribers](#)

standalone (SA) and non-standalone (NSA) 5G core networks using HTTP/2 and Diameter gateways. CAMEL over SIGTRAN (circuit-switched voice and SMS) is supported through Oracle's Convergent Charging Controller (OC3C).

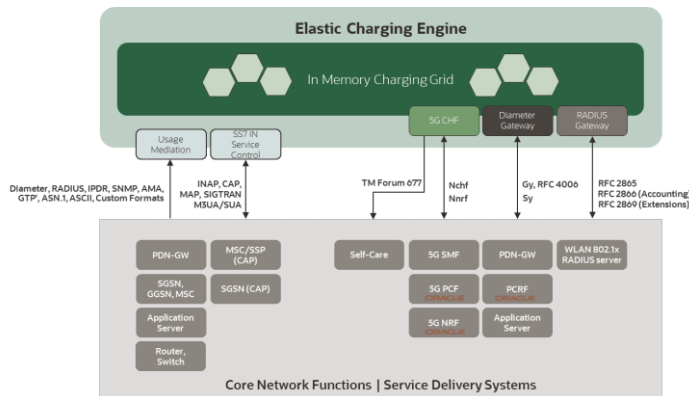

Image 2. ECE core network integration for non telco, fixed, 2G- 5G mobile networks.

Convergent charging mediation for multiple network types including 5G and hybrid 4G/LTE/5G networks as well as non-telco applications is supported with the addition of Oracle Communications Offline Mediation Controller (OCOMC).

Charging flexibility

ECE is highly configurable and provides sophisticated online and offline converged charging for any service, segment, and payment model. ECE provides the ability to rate and charge for anything, using any rating metric or information that is part of the event stream. With Oracle Communications Pricing Design Center, offer bundle and tariff configuration and management is simple and intuitive, allowing business users to create service level offers in minutes.

In-memory charging grid

The real-time rating and balance management functions are underpinned by the industry leading Oracle Coherence in-memory data grid technology, forming a high performance and resilient charging grid which enables a cloud scale experience. Coherence has a dynamic mesh-based architecture that provides fast data access and enables predictable scalability for mission critical applications.

The use of in-memory technology in modern network charging applications is essential to support the very low latency service authorization and re-authorization network requests required, typically specified in the order of milliseconds. ECE's charging grid adopts an innovative approach that co-locates the processing and data, offering high degrees of parallelism, with events persisted asynchronously to an enterprise class database ensuring efficient processing and low latencies.

Network grade performance

The in-memory charging grid stores customer data (including active session details and balances) and pricing data using in-memory cache technology distributed across a cluster of grid members (realized as JVM nodes), with data entries serialized in key-value pairs. Read and write latencies are extremely small, supporting very low end-to-end charging transaction response times for data session initiate, update, and terminate

Converged charging system

ECE provides 3GPP aligned converged charging functions:

- 4G & 5G Non Standalone Architecture Offline Charging Function (NSA OFCF)
- 4G & 5G Non Standalone Architecture Online Charging Function (NSA OCF)
- 5G Standalone Architecture Charging Function (SA CHF)
- Account Balance Management Function (ABMF)
- Charging gateway function (CGF)
- Rating function (RF)

Key features

- In-memory charging grid
- Ability to rate any metric, attribute, and combination of payment options
- Real-time authorization
- Support B2C, B2B and B2B2X with complex hierarchical structures
- TM Forum certified pricing UI designed with intuitive, web-based navigation workflows
- Modern cloud native architecture
- Productized software that can be extended with a fully documented and supported software development kit
- Alignment with TM Forum Open APIs
- API framework to integrate with external applications

Recent innovations in Release 15

- **Personalized offer monetization enhancements:** Simplified renewable offer configuration (including configurable renewal charges/counts), stackable with other offers; APIs to fetch balances and state; support for offline usage rating for renewal/reload offers.
- **Prepaid bonus capability:** Configurable, repeatable global

requests. ECE uses Coherence distributed caching for storing customer objects across members of the charging grid with automatic partitioning and rebalancing of data as new members are added or removed from the grid.

Rather than taking the approach of fetching data from a remote store, performing processing, and then writing the data back to the remote store, the charging grid processes all transaction requests directly where the data entries are managed in the cluster. This co-located data and processing affinity architecture offers the following benefits:

- Processing is extremely fast as all objects are held in-memory, ensuring low latency and cost-efficient compute resource utilization and high charging transaction throughput
- Data access times are close to zero, with processing invoking optimized HashMap lookups
- Almost zero cost locking, retaining transactional data consistency and ensuring no revenue leakage within the charging system

Asynchronous persistence of the grid cache ensures high performance without compromising business-critical data availability. Rated events are offloaded asynchronously to revenue management functions providing a near real-time event flow that does not impact the core network charging processing.

Cloud scale operational experience

The grid is fully distributed, with no single point of contention, supporting independent scalability for large and growing customer data sets. The charging grid supports near linear scalability due to the automatic partitioning of customer data objects across the grid members. Coherence detects new grid members and automatically re-balances the cache data so that it is spread evenly across the grid.

Dynamic scaling up or down can be handled “in-flight” to support changes in presented traffic load, subscriber growth, or compute availability, for example to change roles between test and production for efficient resource utilization.

Cloud native deployment

ECE can be deployed as a cloud native application in a containerized and orchestrated deployment architecture, taking advantage of cloud native infrastructure and DevOps CI/CD tooling to enable service providers to design, test, and deploy services more quickly, operate more efficiently, and scale horizontally as business needs grow. ECE can also be deployed as a non-containerized application if required.

Business continuity architecture

The recommended deployment mode is active-active dual-site deployment. Active-active allows both ECE sites to concurrently process network charging requests across both geographic locations. This architecture is designed to provide a very high level of resiliency and service continuity in the event of unplanned outages. All updates that occur in the charging cluster in a site are replicated to the other site using Coherence cache federation (image 5).

prepaid bonus based on currency resource consumption within a defined period.

- **Tax/GL integration:** Uses tax codes and GLID published from PDC during rating.
- **5G SA / 3GPP enhancements:** 3GPP R17 support for existing CHF features; support for NFsets and the 3gpp-sbi-routing-binding header.
- **High availability via SCP:** Register/communicate with SCP in active-active mode, incl SCP heartbeat API support.
- **Stronger security for SBI:** OAuth 2.0 authentication between CHF and other NFs; SSL-based communication between HTTP/2 gateway and NFs (with or without SCP).
- **Performance improvements:** Optimization for large sharing groups; faster recovery through improved BRS queuing algorithm (replacing retry-timeout).
- **Operational controls / configurability:** EM Gateway degraded mode support; & stale session retention configurability (minutes); Helm chart support for Coherence journaling-config.
- **Diameter support:** Dictionary extensions for dual-stack IPv4/IPv6.
- **Observability & alerts:** Expanded metrics (BRS/DGW/EMGW/REF, retries, Diameter sessions), improved monitoring plus predefined alert templates.
- **Platform, compliance, and dependency updates:** Technology stack certifications; Groovy 4 uplift; NoSQL 24.1 upgrade; Oracle DB 26ai (23.26), VPAT, and third-party dependency updates.

Key cloud native features

- Kubernetes-orchestrated containerized multi-service architecture.

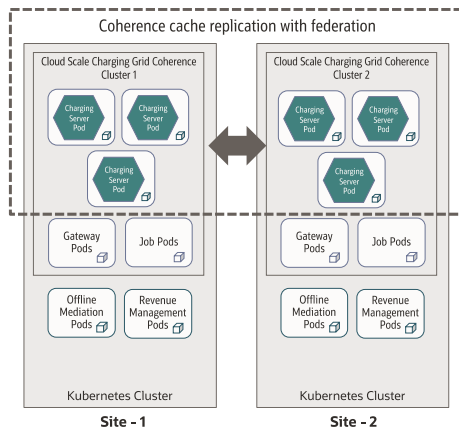

Image 5. Charging grid cache federation across sites

In this configuration, both sites are active with each site housing complete customer and configuration data. Requests can be sent to any site; the core network functions need not know the preferred site for a subscriber. Responses are routed back through the site that originally received the request from the core network.

In case of a charging grid outage at a specific site, the remaining site can continue to process the usage requests and share the load of the failed site, until the site is brought back up and ready to process again. Ideally, each charging grid should handle an evenly balanced traffic load, for example each charging grid within the dual site configuration should handle approximately 50% of the traffic.

Summary

ECE is a cloud native 5G ready converged charging system designed from the ground up to support the future needs of hyperscale service providers. It uses mesh based in-memory technology to provide high performance, resilient, and linearly scalable charging, with pre-integrations available to advanced revenue management capabilities. It allows techco CSPs to efficiently monetize high volumes of communications, data, and media traffic and at the same time provide a compelling customer experience.

Connect with us

Call **+1.800.ORACLE1** or visit **oracle.com**. Outside North America, find your local office at: **oracle.com/contact**.

 blogs.oracle.com

 facebook.com/oracle

 twitter.com/oracle

Copyright © 2026, Oracle and/or its affiliates. All rights reserved. This document is provided for information purposes only, and the contents hereof are subject to change without notice. This document is not warranted to be error-free, nor subject to any other warranties or conditions, whether expressed orally or implied in law, including implied warranties and conditions of merchantability or fitness for a particular purpose. We specifically disclaim any liability with respect to this document, and no contractual obligations are formed either directly or indirectly by this document. This document may not be reproduced or transmitted in any form or by any means, electronic or mechanical, for any purpose, without our prior written permission.

This device has not been authorized as required by the rules of the Federal Communications Commission. This device is not, and may not be, offered for sale or lease, or sold or leased, until authorization is obtained.

Oracle and Java are registered trademarks of Oracle and/or its affiliates. Other names may be trademarks of their respective owners.

Intel and Intel Xeon are trademarks or registered trademarks of Intel Corporation. All SPARC trademarks are used under license and are trademarks or registered trademarks of SPARC International, Inc. AMD, Opteron, the AMD logo, and the AMD Opteron logo are trademarks or registered trademarks of Advanced Micro Devices. UNIX is a registered trademark of The Open Group. 0124

- Choice of Open Container Initiative based Kubernetes runtime.
- Helm charts simplify installation of BRM and its dependencies into a Kubernetes cluster.
- Observability and logging framework support.
- Choice of Oracle database: physical or containerized.
- Utilize any CI/CD pipeline to support the rapid launch of differentiating services.
- Incorporate BRM configuration and extension support.
- Deployable on private clouds behind a firewall or public cloud infrastructure.
- Supports industry standard cloud native technologies for volume / cluster networking and logging and monitoring.
- Kubernetes services and deployments to enable simpler upgrades and configuration changes.
- Efficient scaling utilizing Kubernetes inbuilt horizontal scaling.