



CORPORATE IT

Global Database Services

Oracle Global Data Services

Al Fischer

Manager IT – Database Services

Global IT Strategy

Enrich distributor, customer and employee experiences with innovative technology solutions that drive enterprise growth, efficiency and agility through a deep knowledge and understanding of Amway's business.



Distributor –

Enhance the value proposition and distributor experience by providing rich support anytime, anywhere to manage and grow their businesses



Consumer / Customer –

Make it easier to connect with Amway, our distributors, our products and our brands



Employees –

Increase productivity and effectiveness worldwide through better information and powerful business solutions

*Global IT
Priorities*

Global and Regional Database Teams



Global DBA Team



Regional DBA Team Members



MAGIC - Managing Awards Growth Income and Compensation

How we pay our Amway Business Owners

- Bonus Value / Points Value (BV/PV) on sales
- Monthly rewards based on sales that month
- Multi-level Marketing
 - For downline sales, they get their full benefit, but the upline also accumulates BV/VP
- Achievement level based on number sales that month
- Multiple months at higher levels lead to greater rewards
- Crucial for business that ABO's can see current BV/PV near or at real-time
 - Read only operation
- Outage of BV/PV has direct consequence on sales
- Outage of BV/PV has significant business cost.

Business Challenge

Uptime

Response
time

Security

TCO

- How many 9's at what cost?
 - 99.9 is 8.76 hours a year
 - 99.99 is 52 minutes a year
 - 99.999 is 5 minutes a year
- BV/PV inquiry time
 - Traverse the line of sponsorship
 - Up to the minute level information
- Proactive patching and security
 - PCI compliance
- Amway crown jewels
- Total Cost
 - Hardware / storage
 - Resources to manage

Existing Architectural overview

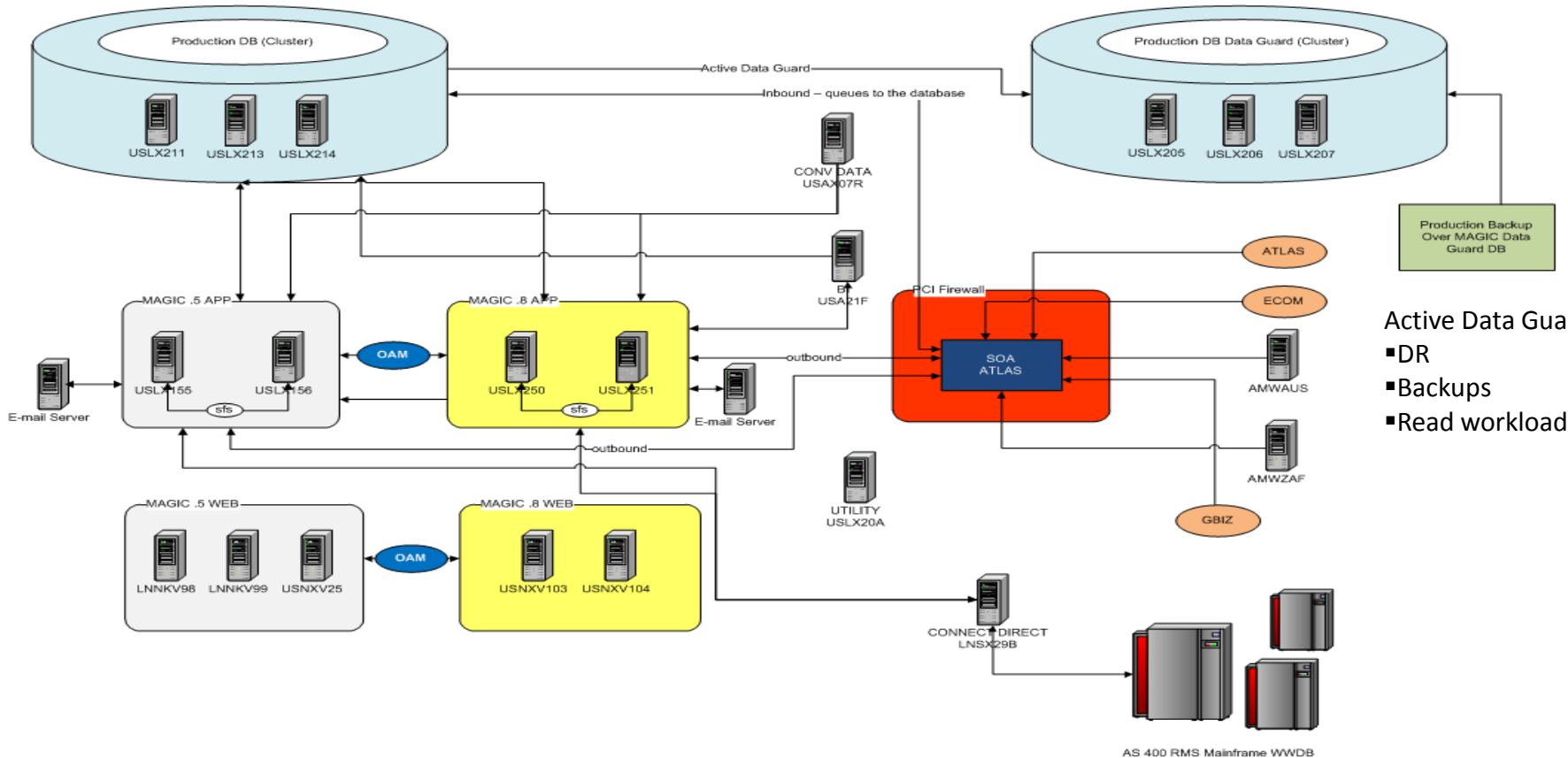

Active Data Guard for:

- DR
- Backups
- Read workloads

GDS advantages

Leverage existing infrastructure resource utilization

- Primary database
- DR database
- Data Guard Broker
- Existing services
 - No application change except for TNS connectivity
 - Already separated for read-only and OLTP operations

Minimal set-up (DBA time)

- Quick deployment
- Adaptable for maintenance
- 2-3 hours after delivery of servers

UpTime

- Read only transactions can get another '9' without major infrastructure changes

GDS POC

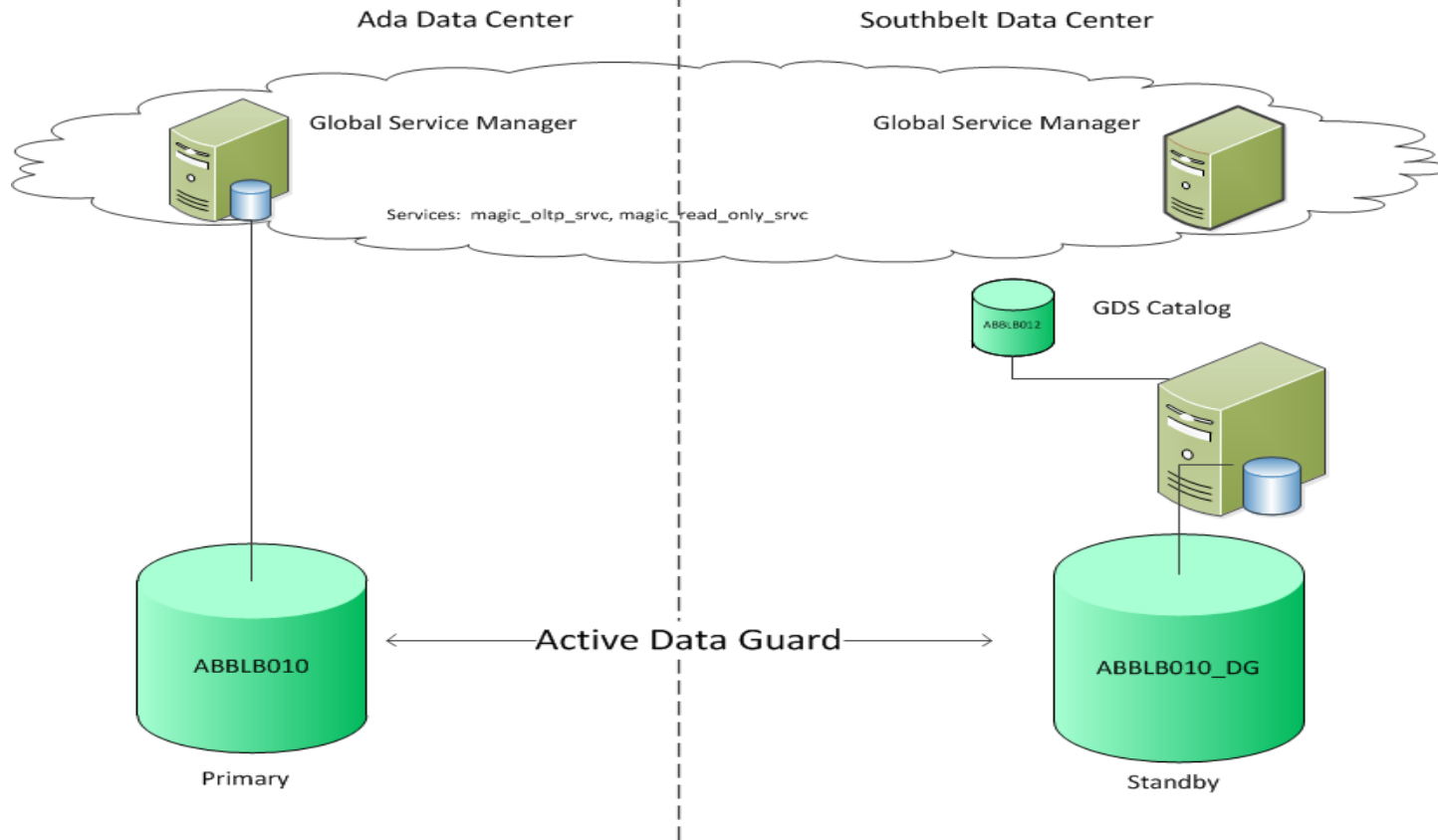

High level Steps

Amway tested GDS on Oracle Multitenant Databases

- Install GSM software on multiple nodes
 - Download / unzip
 - `./runInstaller -> root.sh`
- Set up GDS Admin accounts and priv's
 - `alter user gsmuser account unlock`
 - `:`
- Configure GDS
 - Create GDS catalog
 - Add GSMs
 - `GDSCTL>start gsm -gsm <gsmname>`
 - Add Services
- Set up Client connectivity

Amway Test Cases

Test Case	Result
Crash Primary / Standby	Services failover as expected
Crash GDS Catalog	All services remain available
Active Data Guard Switchover	Services restart on expected nodes
Lag Tolerance	Service stops / restarts on other node if lag exceeds threshold

Amway Future Steps

Test Case	Benefit
Load Balancing	Faster return for query
RAC database	Higher availability
Moving from one container database to another	Higher availability Ease of upgrade

Next Steps for Amway

- Demo to Business User
- Include in Oracle Database 12c upgrade plans
- Procure GSM servers and Catalog
QA and Production
- Verify in our QA environment
 - We have ADG in both Production and QA
- Include GDS as part of our High Availability offerings to other programs/projects
 - Global Datawarehouse?
- Enjoy the benefits

Contact Information

- Al Fischer
Database Services Manager
616-787-1807 - Work
Al.Fischer@Amway.com

- Ron Swanson
Principal Oracle DBA
616-787-5387 – Work
Ron.Swanson@Amway.com