



An Oracle White Paper
October 2013

How to Connect Oracle Exadata to 10 G Networks Using Oracle's Ethernet Switches

Introduction	1
Exadata Database Machine X3-2 Full Rack Configuration.....	1
Multirack Exadata Database Machine X3-2 Configuration	3
Exadata Database Machine X3-8 Full Rack Configuration.....	5
Multirack Exadata Database Machine X3-8 Configuration	7
High Availability Option for Multirack Exadata Database Machine X3-8 Configuration.....	9
How to Configure the Network for Oracle Exadata	11
Database Servers to Oracle Switch ES1-24 10 G Switch.....	11
Oracle Switch ES1-24 10 G Switch to Client's 10 G Network Using L2 Uplinks.....	14
Oracle Switch ES1-24 10 G Switch to Client's 10 G Network Using L3 Uplinks.....	16
Conclusion	19
References.....	19

Introduction

This paper provides instructions for how to connect various Oracle Exadata configurations to an existing 10 G Ethernet network using Oracle's Ethernet switches. The paper also includes a description and sample commands to show how to configure the network ports when connecting Oracle Exadata database servers to a 10 G network.

Exadata Database Machine X3 is Oracle's next generation Database Machine, combining massive memory and low-cost disks to deliver the highest performance and petabyte scalability at the lowest cost. It is the ideal database platform for the varied and unpredictable workloads of cloud computing.

There are two different Oracle Exadata system models, Exadata Database X3-2 and Exadata Database X3-8. Both systems can be deployed in a single-rack or multiple-rack configuration. This paper includes a section for each of the configuration options, describing how to connect that configuration to the client's 10 G network. For each configuration, there is also a detailed parts list so readers can easily purchase all the necessary components.

Oracle Exadata systems can also be connected to gigabit Ethernet (GbE) networks, but this topic will be covered in a separate white paper and is not discussed in this paper.

Exadata Database Machine X3-2 Full Rack Configuration

Exadata Database Machine X3-2 includes eight Oracle Database servers, each with four 10 G Base-T and two 10 G SFP+ onboard ports. It has two rack units (at location 41U and 42U) available for server access switches with front-to-back airflow.

The proposed networking configuration utilizes two Oracle Switch ES1-24 switches. Oracle Switch ES1-24 is a 10 GbE switch that is 1U half-width and has 24-port access, including 20x10 G Base-T ports with 100Mbps/1/10 Gbps auto-negotiation and four 10 G SFP+ ports. Oracle Switch ES1-24 comes with industry-standard L2 and L3 features, logical link aggregation, server load balancing, and support for virtualization. The data sheet and product related information for Oracle Switch ES1-24 is available [here](#).

The four 10 G Base-T ports on the Oracle Database servers can be connected directly to the 10 G Base-T ports on Oracle Switch ES1-24 switches. There is no need for extra transceivers/cables, thus reducing the TCO significantly.

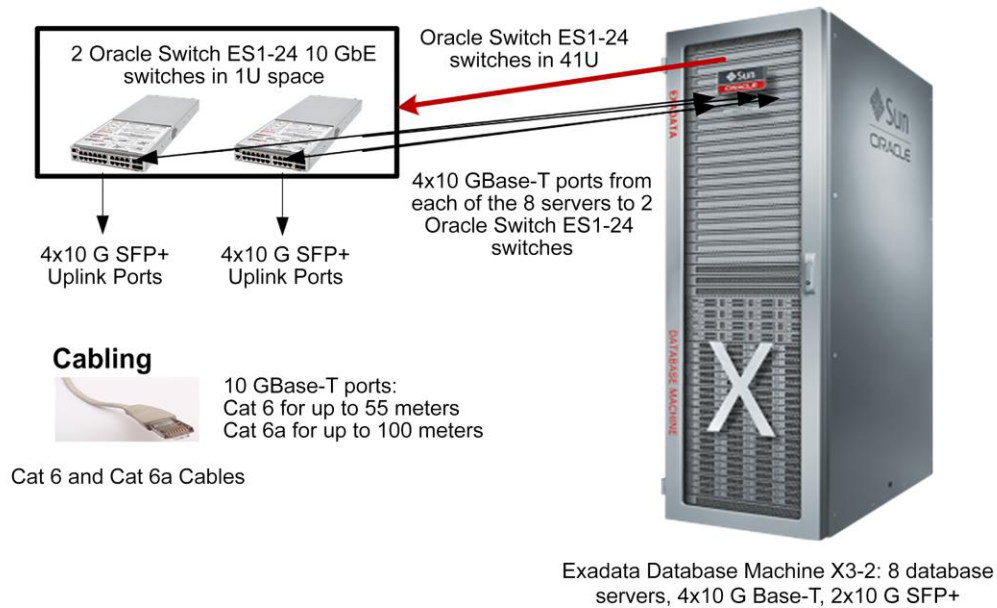

Figure 1: 10 GbE networking configuration for Exadata Database Machine X3-2, single full rack

Oracle Switch ES1-24 is a 1U half-wide switch, and two switches are placed in 1U space in 41U. The switches are available in front-to-back air flow.

Exadata Database Machine X3-2 contains eight Oracle Database servers with four 10 G Base-T ports each, two of which are connected to each of the Oracle Switch ES1-24 10 G Base-T ports for high availability (HA). Cat 6 cables up to 55 meters or Cat 6a cables up to 100 meters can be used. The four 10 G SFP+ ports on the Oracle Switch ES1-24 switches are dedicated for uplink connectivity to the client's network with a 4:1 oversubscription.

Table 1 shows all the components required for this proposed networking configuration.

TABLE 1: COMPONENTS REQUIRED FOR CONNECTING EXADATA DATABASE MACHINE X3-2, FULL RACK TO 10 GBE NETWORK

QUANTITY	PART NUMBER	DESCRIPTION
2		Oracle Switch ES1-24 10 GbE switch with front-to-rear air flow
CONNECTIONS FOR ORACLE SWITCH ES1-24 TO DATABASE SERVERS		
32	Industry standard	Cat 6 or Cat 6a cable to database servers
CONNECTIONS FOR ORACLE SWITCH ES1-24 TO UPLINK		
8	Industry standard	SFP+ transceivers, cables for uplinks

Multirack Exadata Database Machine X3-2 Configuration

In a multirack configuration with four Exadata Database Machine X3-2 systems, the 10 GbE connectivity to the data center LAN is established by deploying two Oracle Switch ES1-24 10 GbE switches in each Oracle Exadata rack and then connecting those switches to the 10 G network through Oracle's Sun Network 10 GbE Switch 72p, which acts as an aggregate switch.

Each Oracle Exadata rack has two Oracle Switch ES1-24 server access switches connected in rack location 41U. The four onboard 10 G Base-T ports on the Oracle Database servers connect to the 10 G Base-T ports on the Oracle Switch ES1-24. The Sun Network 10 GbE Switch 72p top-of-rack switch is used as an aggregate switch with the four 10 G SFP+ connections from Oracle Switch ES1-24 terminating at Sun Network 10 GbE Switch 72p. Sun Network 10 GbE Switch 72p has 16 QSFP (four 10 G) ports and eight 10 G SFP+ ports.

The QSFP ports on Sun Network 10 GbE Switch 72p are connected with the QSFP to 4xSFP+ splitter cables that have QSFP on one end and 4 SFP+ ports on the other end. There are both copper and optical cabling components available. For copper cables, no transceivers are required and the QSFP port on Sun Network 10 GbE Switch 72p is connected to direct-attach Twinax QSFP to 4xSFP+ splitter cable, which has QSFP on one end and four SFP+ ports on the other end and comes in 1, 3, and 5 meters. The QSFP end of the cables connects to Sun Network 10 GbE Switch 72p while the splitter cable end of the cables is connected to the SFP+ port on Oracle Switch ES1-24.

For optical cables, the QSFP to 4xLC optical splitter cable is connected to the QSFP port on Sun Network 10 GbE Switch 72p. On Oracle Switch ES1-24, the SFP+ transceiver, either long range (LR) or short range (SR), is connected to the SFP+ port along with LC-LC terminated fiber optical cable.

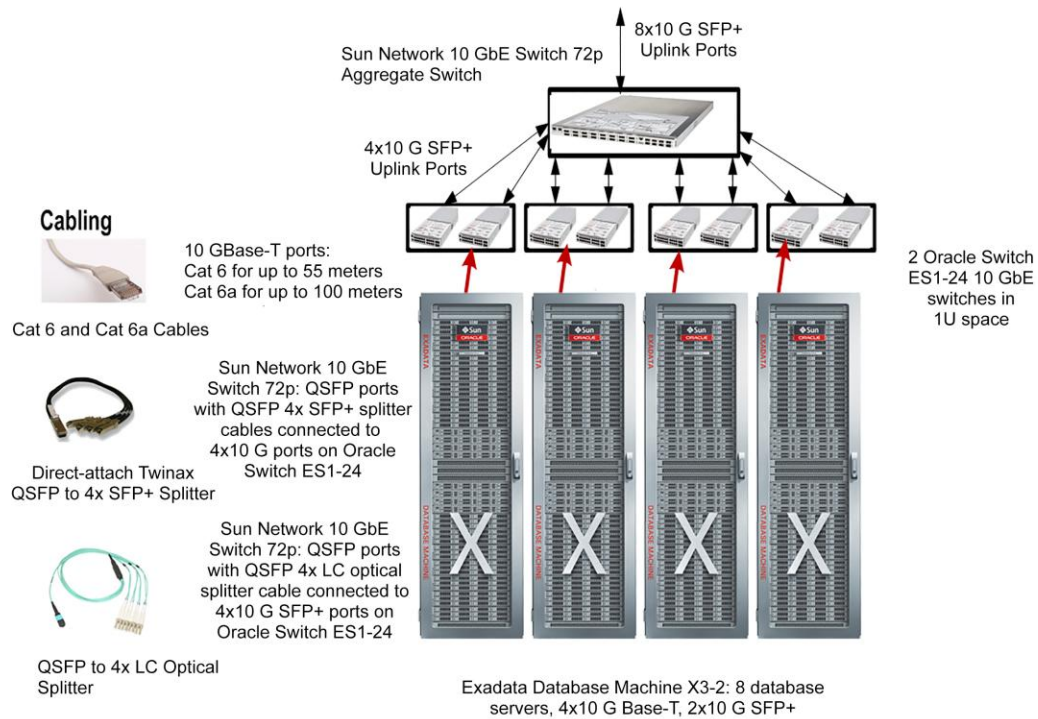

Figure 2: 10 GbE networking configuration for Exadata Database Machine X3-2, four full racks

Table 2 shows all the components required for this proposed networking configuration. Either the copper or optical cables can be used to connect the Oracle Switch ES1-24 switch to the Sun Network 10 GbE Switch 72p switch.

TABLE 2: COMPONENTS REQUIRED FOR CONNECTING FOUR EXADATA DATABASE MACHINE X3-2 FULL RACKS TO 10 GBE NETWORK

QUANTITY	PART NUMBER	DESCRIPTION
8		Oracle Switch ES1-24 10 GbE switch with front-to-rear air flow
1	x2074A-F/x2074A-R	Sun Network 10 GbE Switch 72p
<i>Connections for Oracle Switch ES1-24 Switches</i>		
10 GBE – 10 G BASE-T TO DATABASE SERVERS		
128	Industry standard	Cat 6 or Cat 6a cables
10 GBE – SFP+ MULTIMODE FIBER (10 G BASE-SR) TO SUN NETWORK 10 GBE SWITCH 72P		
32	X2129A-N	SFP+ SR transceiver

10 GBE – SFP+ MULTIMODE FIBER (10 G BASE-LR) TO SUN NETWORK 10 GBE SWITCH 72P		
32	X5562A-Z	SFP+ LR transceiver
<i>Connections for Sun Network 10 GbE Switch 72p</i>		
10 GBE – SFP+ TO ORACLE SWITCH ES1-24		
8	X2124A	QSFP transceivers
8	X2127A-10 m	MPO-to-4xLC splitter cables, 10 meters
	X2127A-20 m	MPO-to-4xLC splitter cables, 20 meters
	X2127A-50 m	MPO-to-4xLC splitter cables, 50 meters
10 GBE – SFP+ TWINAX COPPER TO ORACLE SWITCH ES1-24		
8	X2125A-1M-N	Twinax QSFP -4xSFP+ splitter, 1 meter
	X2125A-3M-N	Twinax QSFP -4xSFP+ splitter, 3 meters
	X2125A-5M-N	Twinax QSFP -4xSFP+ splitter, 5 meters
10 GBE – SFP+ TO UPLINKS		
8	Customer-supplied	SFP+ transceivers, cables

Exadata Database Machine X3-8 Full Rack Configuration

Exadata Database Machine X3-8 has two 8-core database servers, each with eight 10 G SFP+ ports and eight 1 G Base-T ports. The proposed networking configuration consists of the Sun Network 10 GbE Switch 72p top-of-rack switch as an aggregate with all the network connections from the server connecting to the Sun Network 10 GbE Switch 72p switch.

Sun Network 10 GbE Switch 72p has 16 QSFP (four 10 G) ports and eight 10 G SFP+ ports. It is an ultra-dense, non-blocking, low-latency switch with an industry-standard L2 and L3 feature set. It can be managed through Oracle Integrated Lights Out Manager (Oracle ILOM). The data sheet and product-related information for Sun Network 10 GbE Switch 72p are available [here](#).

The QSFP ports on Sun Network 10 GbE Switch 72p are used to connect to eight 10 G SFP+ ports on both of the database servers using QSFP to 4xSFP+ splitter cables.

Copper and optical cabling components are available. For copper cables, the direct-attach Twinax QSFPx4 SFP+ splitter cable is connected with the QSFP end to Sun Network 10 GbE Switch 72p and the splitter cables going to the eight 10 G ports on the database servers. When using an optical cable component, the QSFP to 4xLC optical splitter cable is connected with the QSFP end on Sun Network 10 GbE Switch 72p. The other end of the splitter cables is connected to the database servers, using either a long range (LR) or short range (SR) SFP+ transceiver. The 8x10 G SFP ports on Sun Network 10 GbE Switch 72p are used for uplinks. This provides a 2:1 oversubscription to the core.

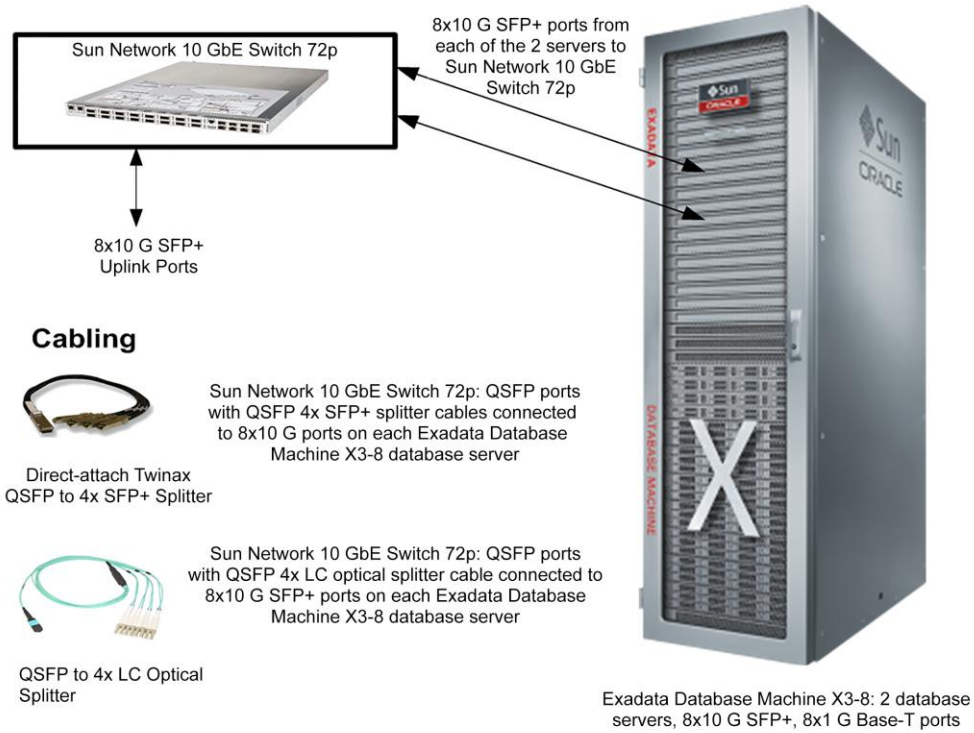

Figure 3: 10 GbE networking configuration for Exadata Database Machine X3-8, single full rack

Table 3 shows all the components required for this proposed networking configuration. Either the copper or optical cables can be used to connect Sun Network 10 GbE Switch 72p to the database servers.

TABLE 3: COMPONENTS REQUIRED FOR CONNECTING EXADATA DATABASE MACHINE X3-8, SINGLE FULL RACK, TO 10 GBE NETWORK

QUANTITY	PART NUMBER	DESCRIPTION
1	x2074A-F/x2074A-R	Sun Network 10 GbE Switch 72p
<i>Connections for Sun Network 10 GbE Switch 72p</i>		
10 GBE – SFP+ MULTIMODE FIBER (10 G BASE-SR) TO DATABASE SERVERS		
4	X2124A	QSFP transceivers

4	X2127A-10 m	MPO-to-4xLC splitter cables, 10 meters
	X2127A-20 m	MPO-to-4xLC splitter cables, 20 meters
	X2127A-50 m	MPO-to-4xLC splitter cables, 50 meters
16	X2129A-N	SFP+ SR transceiver
10 GBE – SFP+ SINGLE MODE FIBER (10 G BASE-LR) TO DATABASE SERVERS		
4	X2124A	QSFP transceivers
4	X2127A-10 m	MPO-to-4xLC splitter cables, 10 meters
	X2127A-20 m	MPO-to-4xLC splitter cables, 20 meters
	X2127A-50 m	MPO-to-4xLC splitter cables, 50 meters
16	X2129A-N	SFP+ SR transceiver
10 GBE – SFP+ TWINAX COPPER TO DATABASE SERVERS		
4	X2125A-1M-N	Twinax QSFP -4xSFP+ splitter, 1 meter
	X2125A-3M-N	Twinax QSFP -4xSFP+ splitter, 3 meters
	X2125A-5M-N	Twinax QSFP -4xSFP+ splitter, 5 meters
10 GBE – SFP+ TO UPLINKS		
8	Customer supplied	SFP+ Transceivers, Cables

Multirack Exadata Database Machine X3-8 Configuration

A multirack configuration with four Exadata Database Machine X3-8 racks can utilize a single Sun Network 10 GbE Switch 72p for connection to the client's 10 GbE network. One Sun Network 10 GbE Switch 72p has enough ports to provide 10 GbE network connectivity to all the database servers in the four racks.

Each Exadata Database Machine X3-8 rack has two database servers with eight cores, eight 10 G SFP+ ports, and eight 1 G Base-T ports. Sun Network 10 GbE Switch 72p has 16 (four 10 G) QSFP ports, which are connected to the database servers across all four racks and eight 10 G SFP+ ports dedicated for uplink with an 8:1 oversubscription to the core.

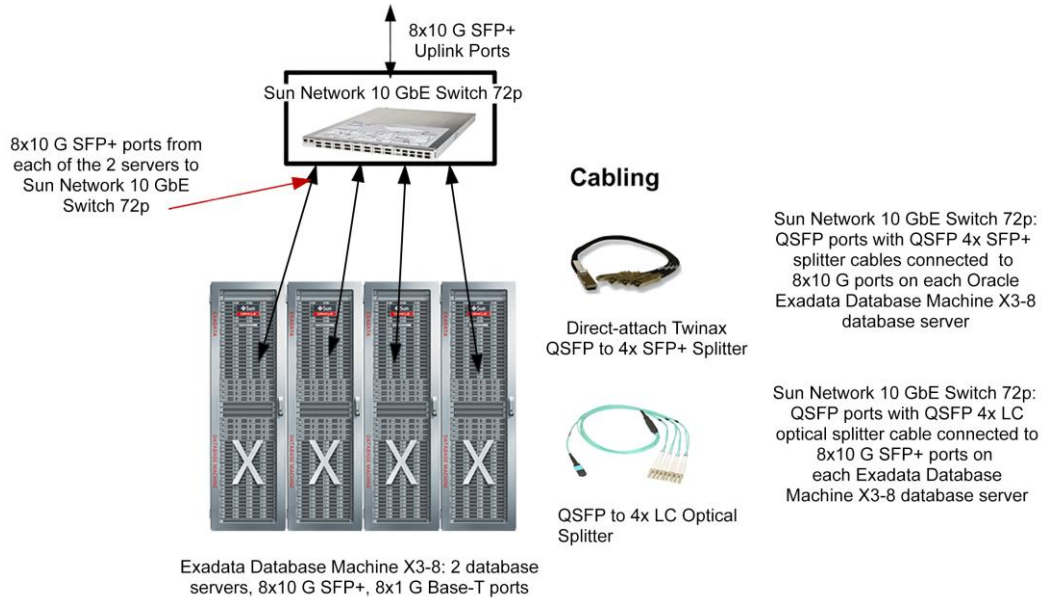

Figure 4: 10 GbE networking configuration for Exadata Database Machine X3-8, multiple full racks

Given below are all the components required for this proposed networking configuration. Either copper or optical cables can be used to connect Sun Network 10 GbE Switch 72p to the database servers.

TABLE 4: COMPONENTS REQUIRED FOR CONNECTING FOUR EXADATA DATABASE MACHINE X3-8 FULL RACKS TO 10 GBE NETWORK

QUANTITY	PART NUMBER	DESCRIPTION
1	x2074A-F/x2074A-R	Sun Network 10 GbE Switch 72p
<i>Connections for Sun Network 10 GbE Switch 72p</i>		
10 GBE – SFP+ MULTIMODE FIBER (10 G BASE-SR) TO DATABASE SERVERS		
16	X2124A	QSFP transceivers
16	X2127A-10 m	MPO-to-4xLC splitter cables, 10 meters
	X2127A-20 m	MPO-to-4xLC splitter cables, 20 meters
	X2127A-50 m	MPO-to-4xLC splitter cables, 50 meters
64	X2129A-N	SFP+ SR transceiver
10 GBE – SFP+ SINGLE MODE FIBER (10 G BASE-LR) TO DATABASE SERVERS		
16	X2124A	QSFP transceivers

16	X2127A-10m	MPO-to-4xLC splitter cables, 10 meters
	X2127A-20 m	MPO-to-4xLC splitter cables, 20 meters
	X2127A-50 m	MPO-to-4xLC splitter cables, 50 meters
64	X2129A-N	SFP+ SR transceiver
10 GBE – SFP+ TWINAX COPPER TO DATABASE SERVERS		
16	X2125A-1M-N	Twinax QSFP -4xSFP+ splitter, 1 meter
	X2125A-3M-N	Twinax QSFP -4xSFP+ splitter, 3 meters
	X2125A-5M-N	Twinax QSFP -4xSFP+ splitter, 5 meters
10 GBE – SFP+ TO UPLINKS		
8	Customer-supplied	SFP+ transceivers, cables

High Availability Option for Multirack Exadata Database Machine X3-8 Configuration

When high availability is desired, multiple Exadata Database Machine X3-8 racks can be connected via two Sun Network 10 GbE Switch 72p switches to enable redundant connections to the client's 10 GbE network. The two Sun Network 10 GbE Switch 72p switches are each connected to all the database servers and to the 10 GbE network via eight uplink ports.

Each Exadata Database Machine X3-8 rack has two database servers with eight cores, eight 10 G SFP+ ports, and eight 1 G Base-T ports. Sun Network 10 GbE Switch 72p has 16 (four 10 G) QSFP ports, which are connected to the database servers across all four racks with four 10 G SFP+ ports from each database server going to a QSFP port on each Sun Network 10 GbE Switch 72p for high availability. Sun Network 10 GbE Switch 72p has eight 10 G SFP+ ports dedicated for uplink. This provides a 4:1 oversubscription to the core.

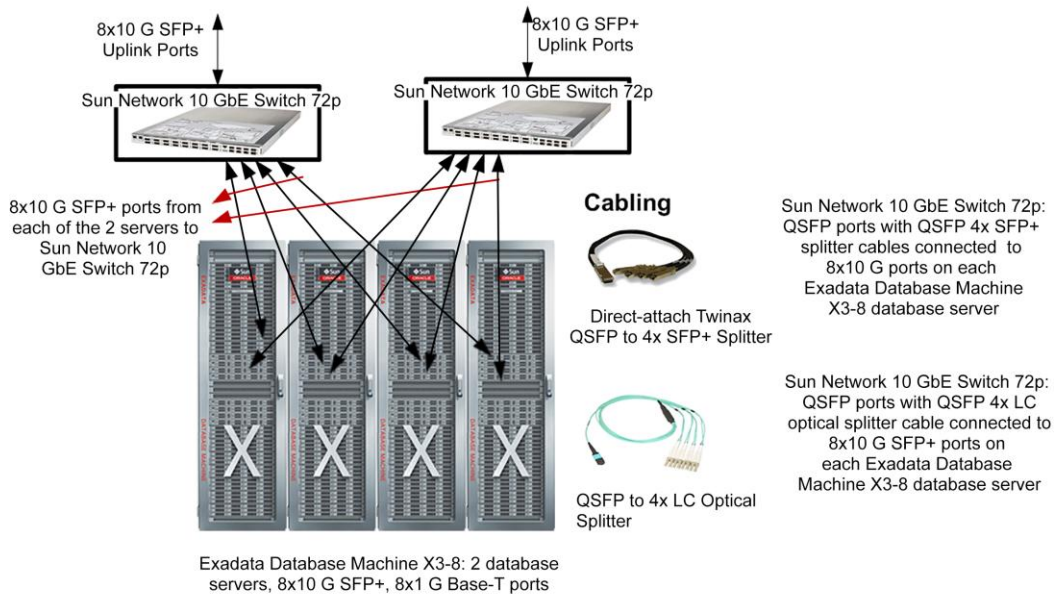

Figure 5: 10 GbE high-availability networking configuration for Exadata Database Machine X3-8, multiple full racks

Table 5 shows all the components required for this proposed networking configuration. Either the copper or optical cables can be used to connect Sun Network 10 GbE Switch 72p to the Oracle Database servers.

TABLE 5: COMPONENTS REQUIRED FOR CONNECTING FOUR EXADATA DATABASE MACHINE X3-8 FULL RACKS TO 10 GBE NETWORK

QUANTITY	PART NUMBER	DESCRIPTION
2	x2074A-F/x2074A-R	Sun Network 10 GbE Switch 72p
<i>Connections for Sun Network 10 GbE Switch 72p</i>		
10 GBE – SFP+ MULTIMODE FIBER (10 G BASE-SR) TO DATABASE SERVERS		
16	X2124A	QSFP transceivers
16	X2127A-10 m	MPO-to-4xLC splitter cables, 10 meters
	X2127A-20 m	MPO-to-4xLC splitter cables, 20 meters
	X2127A-50 m	MPO-to-4xLC splitter cables, 50 meters
64	X2129A-N	SFP+ SR transceiver

10 GBE – SFP+ SINGLE MODE FIBER (10 G BASE-LR) TO DATABASE SERVERS		
16	X2124A	QSFP transceivers
16	X2127A-10 m	MPO-to-4xLC splitter cables, 10 meters
	X2127A-20 m	MPO-to-4xLC splitter cables, 20 meters
	X2127A-50 m	MPO-to-4xLC splitter cables, 50 meters
64	X2129A-N	SFP+ SR transceiver
10 GBE – SFP+ TWINAX COPPER TO DATABASE SERVERS		
16	X2125A-1M-N	Twinax QSFP -4xSFP+ splitter, 1 meter
	X2125A-3M-N	Twinax QSFP -4xSFP+ splitter, 3 meters
	X2125A-5M-N	Twinax QSFP -4xSFP+ splitter, 5 meters
10 GBE – SFP+ TO UPLINKS		
8	Customer-supplied	SFP+ transceivers, cables

How to Configure the Network for Oracle Exadata

This section provides an example showing how to configure the network connections when connecting an Exadata Database Machine X3-2 system to the client's 10 G network using the Oracle Switch ES1-24s switch. This can be used as a guideline for configuring Exadata Database Machine X3-8 systems using Sun Network 10 GbE Switch 72p. However, note that the logical link aggregation (LLA) feature is supported only on Oracle Switch ES1-24.

There are two steps in the configuration process. The first step is to configure the ports on the database servers within Oracle Exadata. The onboard 10 G Base-T ports from the servers are connected to the 10 G Base-T ports on the Oracle Switch ES1-24 10 G switches. These ports can take advantage of logical link aggregation (when connecting to an Oracle Switch ES1-24) with active-active connections, or they can be configured with active-standby connections in an HA setup.

The second step is to configure the uplink ports from Oracle Switch ES1-24 so that the ports are connected to the client's 10G network. These ports can be configured using L2 or L3 uplink connectivity.

Each of these configuration options is covered in the following sections.

Database Servers to Oracle Switch ES1-24 10 G Switch

Consider the topology shown in Figure 6. The Exadata Database Machine X3-2 system has eight database servers, each with four 10 G Base-T ports. From each server, one of the 10 G Base-T ports is connected to 10 G Base-T ports on each of the Oracle Switch ES1-24 10 G switches. The ports on the server can be configured in active-standby mode or active-active mode.

If LLA is configured on the Oracle Switch ES1-24 switches with an inter-switch link (ISL) port-channel between them, then the server ports connecting to the Oracle Switch ES1-24 switches should be configured in active-active mode. This supports rapid failover and increased capacity with the server-bound traffic being hashed on either the direct link to the server or over the ISL.

On the Oracle Solaris server, the ports are aggregated using “aggr” whereas on the Oracle Linux server, they are aggregated using “bonding,” as shown below.

```
[Host-6 ~]# cat /proc/net/bonding/bond0
Ethernet Channel Bonding Driver: v3.6.0 (September 26, 2009)
Bonding Mode: fault-tolerance (active-backup)
Primary Slave: eth1 (primary_reselect always)
Currently Active Slave: eth1
MII Status: up
MII Polling Interval (ms): 100
Up Delay (ms): 0
Down Delay (ms): 0
Slave Interface: eth1
MII Status: up
Link Failure Count: 1
Permanent HW addr: 00:10:e0:22:0f:d9
Slave queue ID: 0
Slave Interface: eth6
MII Status: up
Link Failure Count: 1
Permanent HW addr: 00:10:e0:22:0f:da
Slave queue ID: 0
```

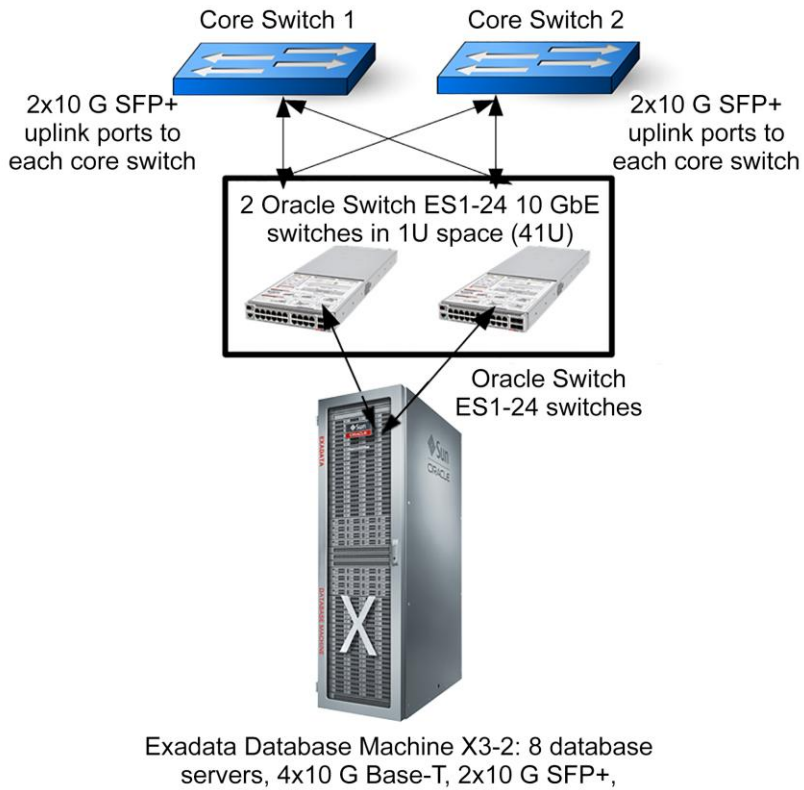

Figure 6: 10 GbE HA networking configuration for Exadata Database Machine X3-2, single full rack—L2 uplinks

In the topology shown in Figure 6, the onboard 10 G Base-T ports on the database server are connected to port 1 on each of the Oracle Switch ES1-24 switches. VLANs 2 and 3 are configured on the database server.

Given below is the L2 configuration for the Oracle Switch ES1-24 switches.

First disable GVRP, GMRP and then configure the VLANs 2 and 3.

```
SEFOS# configure terminal
SEFOS(config)# set gvrp disable
SEFOS(config)# set gmrp disable
SEFOS(config)# set port-channel enable
SEFOS(config)# interface vlan 1
SEFOS(config-if)# shutdown
SEFOS(config-if)# no ip address
SEFOS(config-if)# end
```

Step 1: Create VLANs 2 and 3 on the Oracle Switch ES1-24 switches.

```
SEFOS (config) # vlan 2
SEFOS (config-vlan) # ports add extreme-ethernet 0/1
SEFOS (config-vlan) # vlan active
SEFOS (config-vlan) # exit
SEFOS (config) # vlan 3
SEFOS (config-vlan) # ports add extreme-ethernet 0/1
SEFOS (config-vlan) # vlan active
SEFOS (config-vlan) # exit
SEFOS (config-vlan) # end
SEFOS# write startup-config
```

Step 2: Configure the port connecting to database server as trunk port.

```
SEFOS# configure terminal
SEFOS (config) # interface range extreme-ethernet 0/1
SEFOS (config-if) # switchport mode trunk
SEFOS (config-if) # no shutdown
SEFOS (config-if) # exit
```

Oracle Switch ES1-24 10 G Switch to Client's 10 G Network Using L2 Uplinks

Consider the topology shown above in Figure 6. The four 10 G SFP+ ports on the Oracle Switch ES1-24 10 G switches are reserved for uplink connection to the client's 10 GbE network. For configuring the uplink ports to the core switches, the guidelines below should be followed. In an HA setup with two core switches, connect two 10 G ports from Oracle Switch ES1-24 to each of the core switches, as shown in Figure 6. The uplink ports are aggregated and configured in trunk mode to allow the traffic for VLANs 2 and 3 to be carried.

Note: If the client's core switches provide only 1 G connectivity, the setting on the uplink ports should be "speed 1000." At 1 G speed, the ports operate in forced-1000-FDX mode; hence, auto-negotiation MUST be disabled on the client's core switch ports connecting to the uplink ports on Sun Network 10 GbE Switch 72p.

Step 3: Configure port aggregation for uplink ports. Port-channel 10 aggregates ports 21–22 to core switch1. Port-channel 11 aggregates ports 23–24 to core switch2.

```
SEFOS# configure terminal
SEFOS (config) # set port-channel enable
SEFOS (config) # interface port-channel 10
SEFOS (config-if) # no shutdown
SEFOS (config) # exit
SEFOS (config) # interface port-channel 11
SEFOS (config-if) # no shutdown
SEFOS (config) # end
```

Step 4: Add ports to uplink port-channels.

```
SEFOS# configure terminal
SEFOS(config)# interface range extreme-ethernet 0/21-22
SEFOS(config-if)# no shutdown
SEFOS(config-if)# channel-group 10 mode active
SEFOS(config-if)# exit
SEFOS(config)# interface range extreme-ethernet 0/23-24
SEFOS(config-if)# no shutdown
SEFOS(config-if)# channel-group 11 mode active
SEFOS(config-if)# end
```

Step 5: Configure uplink port-channels to allow all VLANs.

```
SEFOS# configure terminal
SEFOS(config)# interface port-channel 10
SEFOS(config-if)# switchport mode trunk
SEFOS(config-if)# no shutdown
SEFOS(config)# exit
SEFOS(config)# interface port-channel 11
SEFOS(config-if)# switchport mode trunk
SEFOS(config-if)# no shutdown
SEFOS(config)# end
```

Note: In the above topology shown in Figure 6, if the core switches are running vPC, then port-channels 10 and 11 should be configured for LACP mode, and the individual ports of port-channels 10 and 11 should connect to both switches:

Ports 21, 23 to core switch1
Ports 22, 24 to core switch2

For detecting and avoiding loops in the network, configure the MSTP protocol. However, if the core switch is configured for PVRST (Cisco proprietary protocol), configure PVRST on Oracle Switch ES1-24, as shown below. Check the spanning tree for each VLAN using the command `show spanning-tree`.

Note: While using PVRST, the ports can be either access ports or trunk ports. By default, a trunk port will become a member of all VLANs configured on the switch. VLAN pruning capability is not currently supported.

Step 6: Configure L2- PVRST on Oracle Switch ES1-24 such that it is not the root bridge for any VLANs configured. Doing so makes the core switch become the root, and only intended traffic (not all core traffic) reaches the Oracle Switch ES1-24 switches.

```
SEFOS# configure terminal
SEFOS(config)# spanning-tree mode pvrst
Spanning Tree enabled protocol is MSTP, now MSTP is being shutdown
PVRST is started.
PVRST Module status is changed
SEFOS(config)# spanning-tree vlan 2 brg-priority 61440
SEFOS(config)# spanning-tree vlan 3 brg-priority 61440
SEFOS(config)# end
```

Oracle Switch ES1-24 10 G Switch to Client's 10 G Network Using L3 Uplinks

Consider the topology shown in Figure 7, where the uplink ports from the Oracle Switch ES1-24 switch connecting to the client's core switch are configured as L3 uplinks. Uplink ports 21 to 24 are aggregated into port-channel 1 and are members of VLAN 20. VLAN 20 is assigned an IP address that is in the same subnet as the ports on the core switch connecting to the uplink ports on Oracle Switch ES1-24. Port 1 on Oracle Switch ES1-24 is connected to the database server and is a member of VLAN 10. VLAN 10 is assigned an IP address in the same subnet as the database servers in VLAN 10.

Note: The database servers must be set up in active-standby mode since L3-based configurations are not supported with LLA.

At the least, static routing should be set up on Oracle Switch ES1-24 to reach the default external gateway. Additionally, if needed, dynamic routing protocols such as RIP and OSPF (in accordance with the routing protocol defined on the core) could be configured.

The inter-switch link (ISL) between the two switches is established over port 15 and VLAN 99 is configured as ISL VLAN.

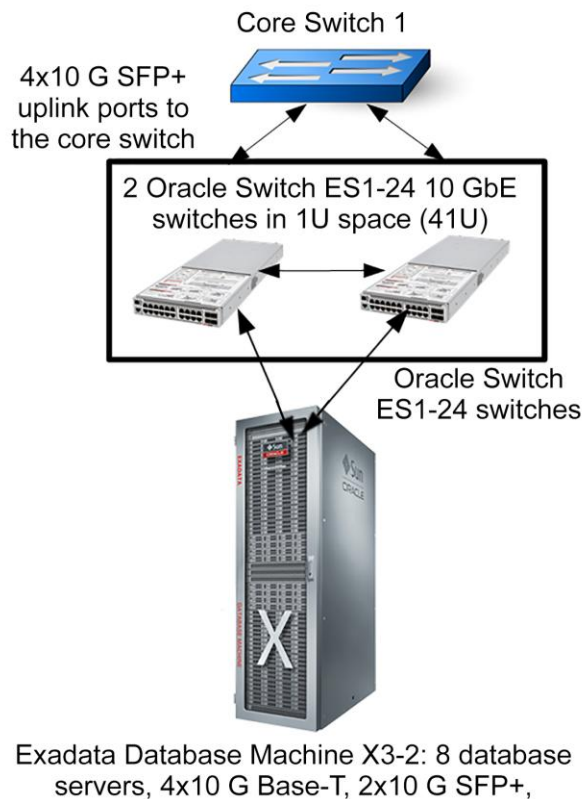

Figure 7: 10 GbE HA networking configuration with virtual router redundancy protocol (VRRP) for Exadata Database Machine X3-2 single full rack—L3 uplinks

Enable/disable default features and then configure the VLANs:

```
SEFOS# configure terminal
SEFOS(config)# set gvrp disable
SEFOS(config)# set gmrp disable
SEFOS(config)# set lldp enable
SEFOS(config)# set port-channel enable
SEFOS(config)# ip routing
SEFOS(config)# int vlan 1
SEFOS(config-if)# no ip address
SEFOS(config-if)# shut
SEFOS(config)# exit
```

Step 1: Configure untagged VLANs between the two Oracle Switch ES1-24 switches as “access VLAN”.

```
SEFOS# configure terminal
SEFOS(config)# vlan 99
SEFOS(config-vlan)# ports add extreme-ethernet 0/15 name ISL
SEFOS(config-vlan)# vlan active
SEFOS(config-vlan)# exit
SEFOS(config)# interface extreme-ethernet 0/15
SEFOS(config-if)# switchport access vlan 99
SEFOS(config-if)# no shutdown
SEFOS(config-if)# exit
```

Step 2: Configure VLAN 10 as tagged on the Oracle Switch ES1-24 connecting to the database servers.

```
SEFOS# configure terminal
SEFOS(config)# vlan 10
SEFOS(config-vlan)# ports add extreme-ethernet 0/1
SEFOS(config-vlan)# ports add extreme-ethernet 0/15
SEFOS(config-vlan)# vlan active
SEFOS(config-vlan)# exit
SEFOS(config-vlan)# end
```

Step 3: Assign L3 addresses to ISL VLAN and VLAN 10.

```
SEFOS# configure terminal
SEFOS(config)# interface vlan 99
SEFOS(config-if)# ip address 99.99.99.101 255.255.255.0
SEFOS(config-if)# no shutdown
SEFOS(config-if)# exit
SEFOS# configure terminal
SEFOS(config)# interface vlan 10
SEFOS(config-if)# ip address 192.168.10.101 255.255.255.0
SEFOS(config-if)# no shutdown
SEFOS(config-if)# exit
```

Step 4: Configure VRRP.

```
SEFOS# configure terminal
SEFOS(config)# router vrrp
SEFOS(config-router)# int vlan 99
```

```
SEFOS(config-router)# vrrp 1 ipv4 99.99.99.1
SEFOS(config-router)# vrrp 1 accept-mode enable
SEFOS(config-router)# vrrp 1 priority 110
SEFOS(config-router)# exit
SEFOS(config-router)# int vlan 10
SEFOS(config-router)# vrrp 1 ipv4 192.168.10.1
SEFOS(config-router)# vrrp 1 accept-mode enable
SEFOS(config-router)# vrrp 1 priority 110
SEFOS(config-router)# exit
```

Note: About priority, it will be configured only on the primary switch; other switches will have default priority 100.

Note: The IP addresses for VLANs 10 and 99 will be x.x.x.101 on one switch and x.x.x.102 on the other.

On the server side, the static route to reach interface VLAN 10 via VRRP address 192.168.10.1 should be configured.

Step 5: Create the port-channel for the uplink ports and add members to the uplink port-channel.

```
SEFOS# configure terminal
SEFOS(config)# interface port-channel 1
SEFOS(config-if)# switchport access vlan 20
SEFOS(config-if)# no shutdown
SEFOS(config)# exit
SEFOS(config)# interface extreme-ethernet 0/21-24
SEFOS(config-if)# channel-group mode 1 active
SEFOS(config-if)# no shutdown
SEFOS(config)# end
```

Step 6: Assign IP addresses to VLAN 20.

```
SEFOS# configure terminal
SEFOS(config)# interface vlan 20
SEFOS(config-if)# ip address 192.168.20.101 255.255.255.0
SEFOS(config-if)# no shutdown
SEFOS(config-if)# exit
```

Step 7: Set the default route to the external gateway reachable through the uplink port-channel 1.

```
SEFOS# configure terminal
SEFOS(config)# ip route 0.0.0.0 0.0.0.0 192.168.20.1 1
SEFOS(config)# exit
```

Step 8: Save the configurations.

```
SEFOS# copy running-config startup-config
```

Conclusion

There are many variables when connecting and configuring an Oracle Exadata system to a data center network. This document is an attempt to simplify that process and reduce risk for Oracle customers by providing detailed instructions for how to use Oracle networking products with Oracle Exadata.

By following the guidelines outlined in this paper, readers can properly set up and configure the network environment to connect an Oracle Exadata system to their existing 10 G network.

References

For more information, visit the web resources listed in Table 6.

TABLE 6. WEB RESOURCES FOR FURTHER INFORMATION	
WEB RESOURCE DESCRIPTION	WEB RESOURCE URL
Oracle Exadata	www.oracle.com/technetwork/server-storage/engineered-systems/exadata/
Oracle's Sun Network 10 GbE Switch 72p	www.oracle.com/us/products/networking/ethernet/top-of-rack-switches/overview/
Oracle Switch ES1-24	www.oracle.com/us/products/networking/ethernet/switch-es1-24/overview/
<i>Sun Ethernet Fabric Operating System CLI Base Reference Manual</i>	http://docs.oracle.com/cd/E19934-01/html/E26513/



How to Connect Oracle Exadata to 10G
Networks Using Oracle's Ethernet Switches
October 2013, Version 1.0
Author: Savi Venkatachalapathy

Oracle Corporation
World Headquarters
500 Oracle Parkway
Redwood Shores, CA 94065
U.S.A.

Worldwide Inquiries:
Phone: +1.650.506.7000
Fax: +1.650.506.7200

oracle.com



Oracle is committed to developing practices and products that help protect the environment

Copyright © 2013, Oracle and/or its affiliates. All rights reserved.

This document is provided for information purposes only, and the contents hereof are subject to change without notice. This document is not warranted to be error-free, nor subject to any other warranties or conditions, whether expressed orally or implied in law, including implied warranties and conditions of merchantability or fitness for a particular purpose. We specifically disclaim any liability with respect to this document, and no contractual obligations are formed either directly or indirectly by this document. This document may not be reproduced or transmitted in any form or by any means, electronic or mechanical, for any purpose, without our prior written permission.

Oracle and Java are registered trademarks of Oracle and/or its affiliates. Other names may be trademarks of their respective owners.

Intel and Intel Xeon are trademarks or registered trademarks of Intel Corporation. All SPARC trademarks are used under license and are trademarks or registered trademarks of SPARC International, Inc. AMD, Opteron, the AMD logo, and the AMD Opteron logo are trademarks or registered trademarks of Advanced Micro Devices. UNIX is a registered trademark of The Open Group. 0113

Hardware and Software, Engineered to Work Together